

#426339 (for NC x NO)

Humidity Controller

RHC-C11 (100–240 VAC)

with Humidity Sensor HN-EK

Instruction Manual

Thank you for purchasing our product.

Please read this manual carefully and follow the instructions to ensure optimal performance.

Keep this manual handy for quick reference.

Please be aware that due to continuing efforts to improve our products, some details in this manual may differ from the actual product.

Thank you for your understanding.

Contents

Safety Precautions	p.2
1. Preparation Before Use	p.4
1) Package Contents	p.4
2) Following Items (Sold Separately) Are Required	p.4
3) Items to Be Supplied by Customer	p.5
4) Tools Required for Installation	p.5
5) Installation Location	p.5
6) Installation of the Controller	p.5
7) Installation of the Humidity Sensor	p.6
8) Wiring	p.8
9) Wiring at the Sensor	p.12
2. Operation	p.14
1) How to Use	p.14
2) How to Change the Humidity Set Value (SV)	p.14
3. Maintenance	p.15
1) Humidity Sensor	p.15
2) Replacing the Fuse Inside the Controller	p.16
4. Troubleshooting	p.17
5. Specifications	p.18

Safety Precautions



Warning

If the product is used without observing the information given under this symbol, serious injury or death may result.



Caution

If the product is used without observing the information given under this symbol, personal injury, physical and/or property damage may result.



This icon indicates warnings and/or cautions.



This icon indicates an action or actions which are required.



This icon indicates restrictions and prohibited actions.



Warning



Do not touch electrically live parts while power is on. Touching live parts can result in an electric shock.



Always turn off the power before any cleaning, maintenance or inspection to avoid electric shock.



Make sure children cannot come close to the product. It may result in electric shock and/or injury.



Do not splash water on the unit. It may cause fire, electric shock, or damage.



Do not position the unit in a place where the product is exposed to rain or water, or a place where the humidity could reach above 85% RH. It may cause electric shock or fire.



Do not disassemble or attempt to refit or improve the unit and parts. This may lead to fire hazard, electric shock, or damage resulting from malfunction.



Wiring should be performed by a licensed electrician in accordance with local technical standards for electrical installation and related regulations to avoid burns, potential fire, injury and/or damage to the product.



Stop the operation immediately if trouble occurs, and unplug the power cable from the electric outlet. Otherwise, fire, electric shock, injury may result.



Use only with specified power supply to avoid the risk of fire, electric shock, or damage to the unit.



Use a solenoid valve with the same voltage specification as the input voltage. There is risk of fire, electric shock, or damage to the unit.



Ensure proper grounding before use to avoid the risk of electric shock.



Do not damage or forcefully bend/pull/twist the power cable to avoid fire and/or electric shock.



Do not install the unit in high-temperature environments or near heat sources. It may cause electric shock, electric leakage, or damage to the product.



Caution



Only operate in an environment with a temperature range of 5-40°C.
Do not use in freezing cold environments to prevent damage to the unit.



Do not use the unit in areas where flammable or explosive gases could be present to avoid fire and/or explosions.



Remove any dirt from the power plug with a dry cloth to prevent electric shock and/or potential fire.



Secure the controller on the solid wall or pillar.
If the controller is not installed properly, it may fall or cause other unexpected accidents.



Inspect the parts periodically. If any irregularity or damage is found, turn off the unit immediately and consult with supplier.



Do not install the controller near a noise source to prevent malfunction.
Also, do not install the controller near areas where induction load or electromagnetic interference can occur.



Do not connect multiple solenoid valves to the same terminal. Connecting multiple solenoid valves will significantly shorten the lifespan of the controller because it draws more electricity than it is built for.
If a normally close type solenoid valve is selected as sub (air relief) solenoid valve of a 2-way solenoid valve unit, it is necessary to change some of the locked factory setting of the RHC-C11. Please contact your sales office for more details.

The following are cautions for the humidity sensor sold separately.



Use careful consideration where the humidity sensor is to be mounted.
Do not install the humidity sensor in places with organic solvents, acids, alkali (bases), and/or oil. This can increase deterioration and shorten the lifespan of the sensor.
Also avoid mounting the sensor in places where water leaks and/or condensation may occur.







Do not install the humidity sensor near a noise source to prevent malfunction.
Also, do not install the controller near areas where induction load or electromagnetic interference can occur.

1. Preparation Before Use

1) Package Contents

Before starting the installation, verify that all the parts listed below are included in your delivery.

 <p>Controller: 1 EA (Model No. RHC-C11 100-240V)</p>	 <p>Humidity sensor: 1 EA (Model No. HN-EKB1NX04)</p>	 <p>Sensor cable (5m): 1 EA (CHC core wire 0.3 mm², Shielded 2-core cable)</p>	 <p>This manual: 1 EA</p>
--	--	---	--

2) Following Items (Sold Separately) Are Required

This manual assumes the following goods are purchased: a solenoid valve unit, either 2-way or 3-way type.

3-way solenoid valve unit* 1 EA
(Model No. VP742/VG342- ★A- □□□V)
□□□: Power supply voltage

*Due to the characteristics of a 3-way solenoid valve, the valve becomes half open and leaks air to both, the exhaust side and nozzle side when the supply pressure is below 0.2 MPa.



★	Corresponding pipe size	Min. flow rate
10	10A (Rc3/8)	290 L/min (at 0.3 MPa)
15	15A (Rc1/2)	700 L/min (at 0.3 MPa)
20	20A (Rc3/4)	700 L/min (at 0.3 MPa)

*If using a 3-way solenoid valve unit not supplied by IKEUCHI, supply a 3-way solenoid valve (NC) capable of supplying sufficient air and a device such as a regulator capable of adjusting pressure.

*Supply a solenoid valve with the same voltage specification as the input voltage.

*Make sure to supply a compressor with a high enough capacity. If the capacity of the compressor is too low, the amount of supplied compressed air might not be able to keep up and the pressure will not increase.

2-way solenoid valve unit 1 EA
(Model No. ADK12 or VXZ***2- ★A- □□□V) □□□: Power supply voltage



★	Corresponding pipe size
10	10A (Rc3/8)
15	15A (Rc1/2)
20	20A (Rc3/4)

Model No.	Specifications of solenoid valves (Main × Air relief)
ADK12 or VXZ***2	NC × NO
ADK11 or VXZ***0	NC × NC

- Supply a solenoid valve with the same voltage specification as the input voltage.
- If using a normally close solenoid valve as the air relief solenoid valve or using our 2-way solenoid valve unit whose model No. is ADK11 or VXW...0, some of the locked factory settings of the RHC-C11 need to be changed. Please contact us for more details.

3) Items to Be Supplied by Customer

Items	Specifications	Qty
Power cable	Core wire 1.25 mm ² , 3-core cable	1
Cables to connect controller and solenoid valve	Core wire 1.25 mm ² , 2-core cable	as required
Bolts and nuts	For installation of the controller	as required

Note: Please use cables with dielectric strength of 300 VAC or more.

4) Tools Required for Installation

Phillips screw driver, small flathead screwdriver, spanner/wrench, nippers, pliers for pressure connector, etc.

5) Installation Location

Do not install the humidity controller and the humidity sensor in a place where it is exposed to water drop, spray from humidifiers, oil smoke, dust, or chemical atmosphere such as organic solvent, acidic, alkaline and oil.

Also avoid installation in places where condensation or water leaks may occur.

6) Installation of the Controller

- i. Drill four screw holes into the surface on which the controller will be mounted, spaced as indicated in the Fig. 1 (four dots).

Note: Make sure there is enough space for wiring and maintenance where you install the controller.

- ii. Loosen the 4 screws at the corners to open the cover. (Screws cannot be removed from the cover.)

- iii. Mount the controller on the wall using with bolts. Controller body has 4 holes (dia. 4.5 mm) for fixing. Recommended bolt size: M4 pan (machine) screw with thread length 20 mm or more.

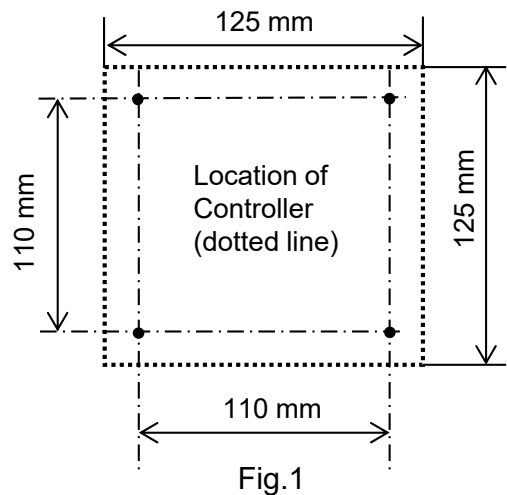

7) Installation of the Humidity Sensor

- i. Remove the rubber bushing from the thermoplate and mount the thermoplate on the wall using self-tapping screws.

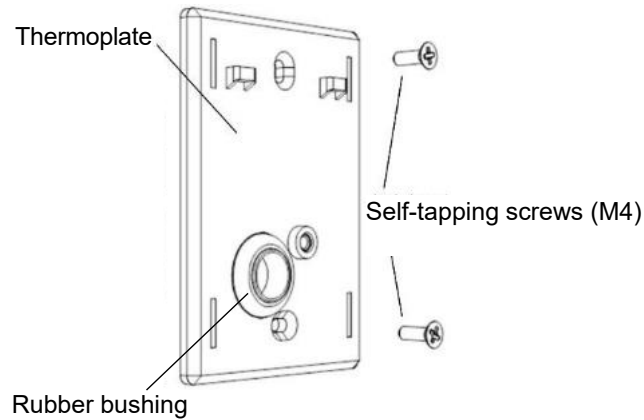

When using a switch box (not included)

Embed a compatible switch box (JIS C 8435-compliant with 83.5 mm screw spacing) into the wall, and attach the sensor's thermoplate to the switch box.

Note: The switch box is not included and should be prepared by the customer if needed. Also Ensure at least 500 mm of space between the top of the switch box and the ceiling.

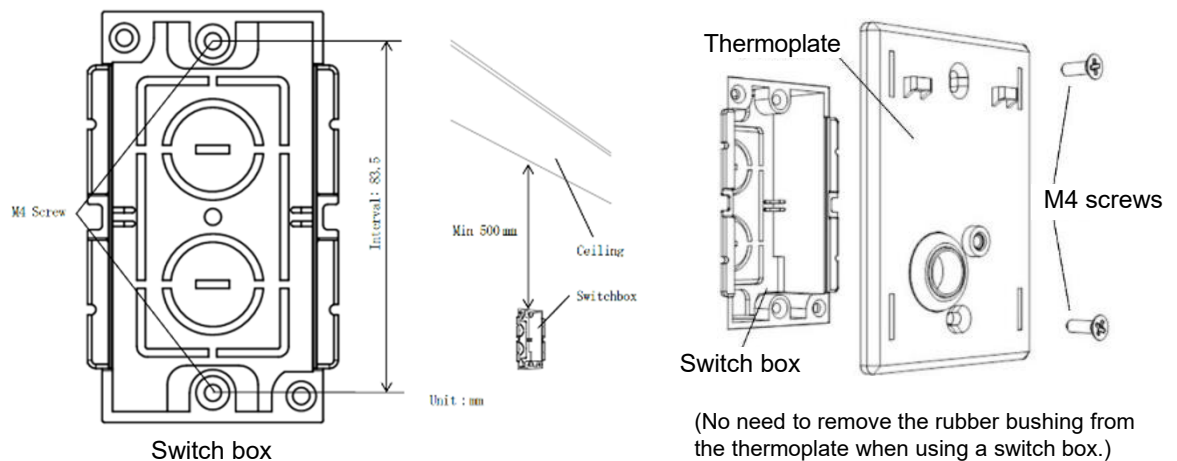

- ii. Remove the screw at the top of the cover, and slide the humidity sensor cover upward until it clicks and the terminal block is exposed.

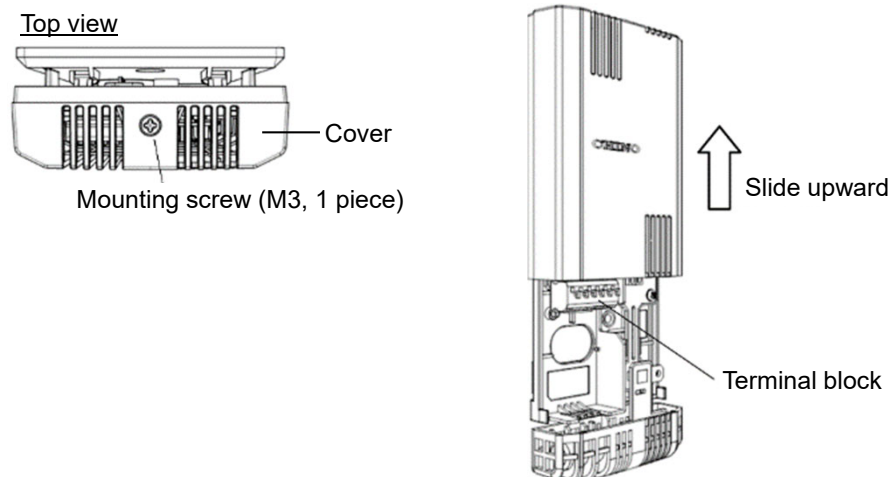

iii. Hook the back hooks of the humidity sensor onto the protrusions of the thermoplate mounted on the wall.

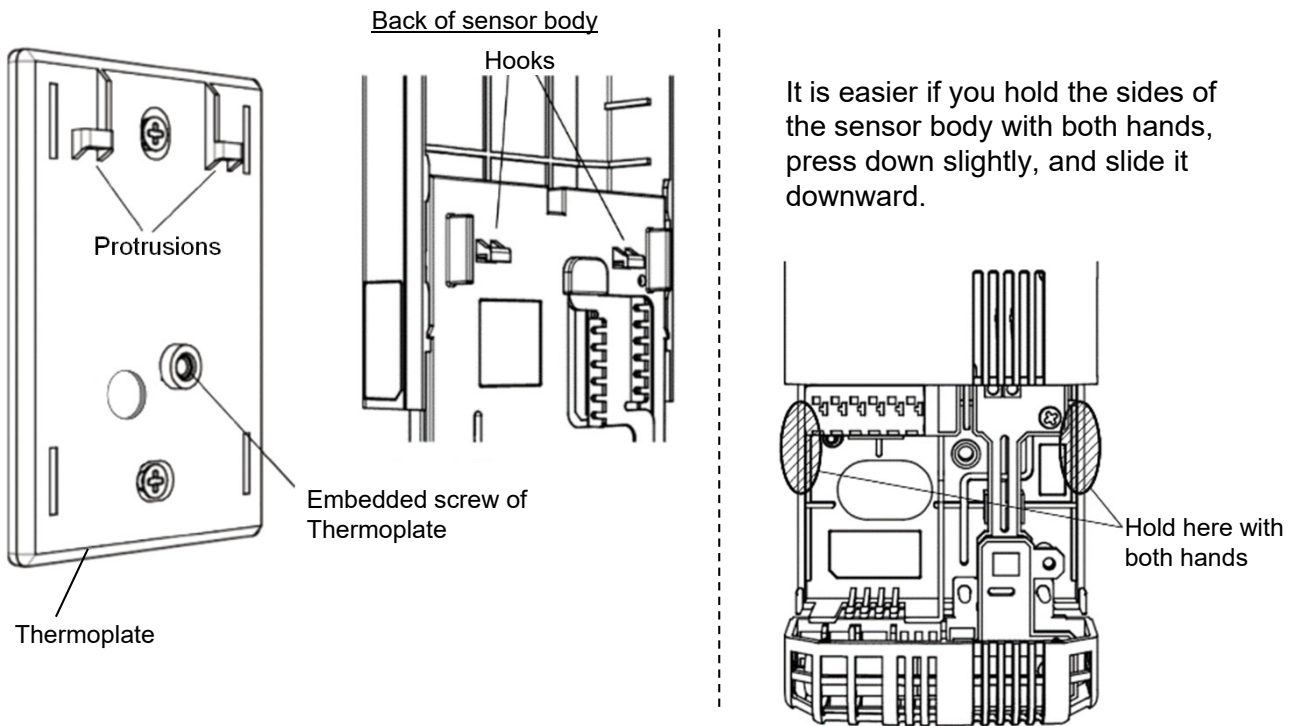

iv. Align the embedded screw (threaded insert) at the center of the thermoplate with the screw hole at the center of the humidity sensor, and secure them using the supplied M4 screw.

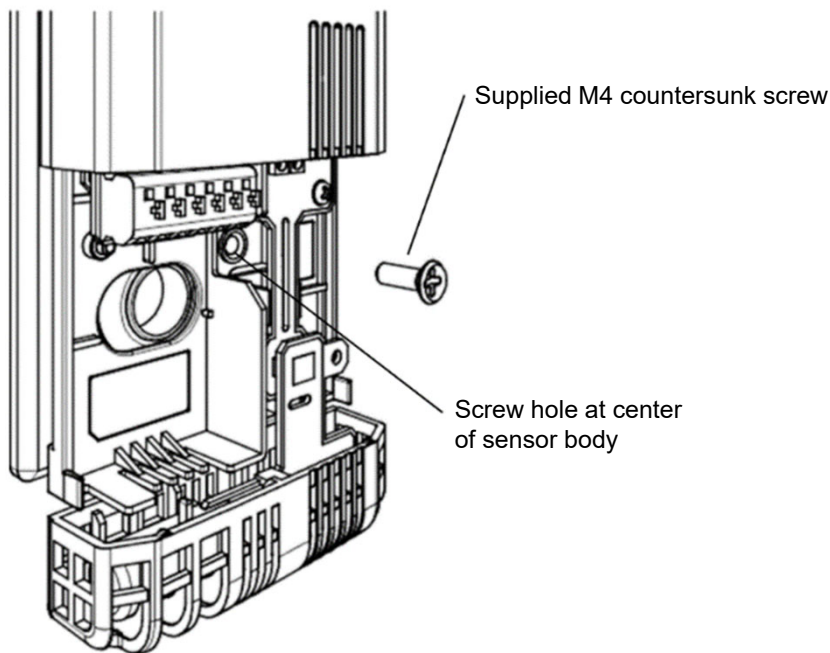

See page 12–13 for wiring procedures to the humidity sensor.

8) Wiring

● Connection Flow: Case 1 (with 3-way solenoid valve unit)

See page 10 for the wiring diagram.

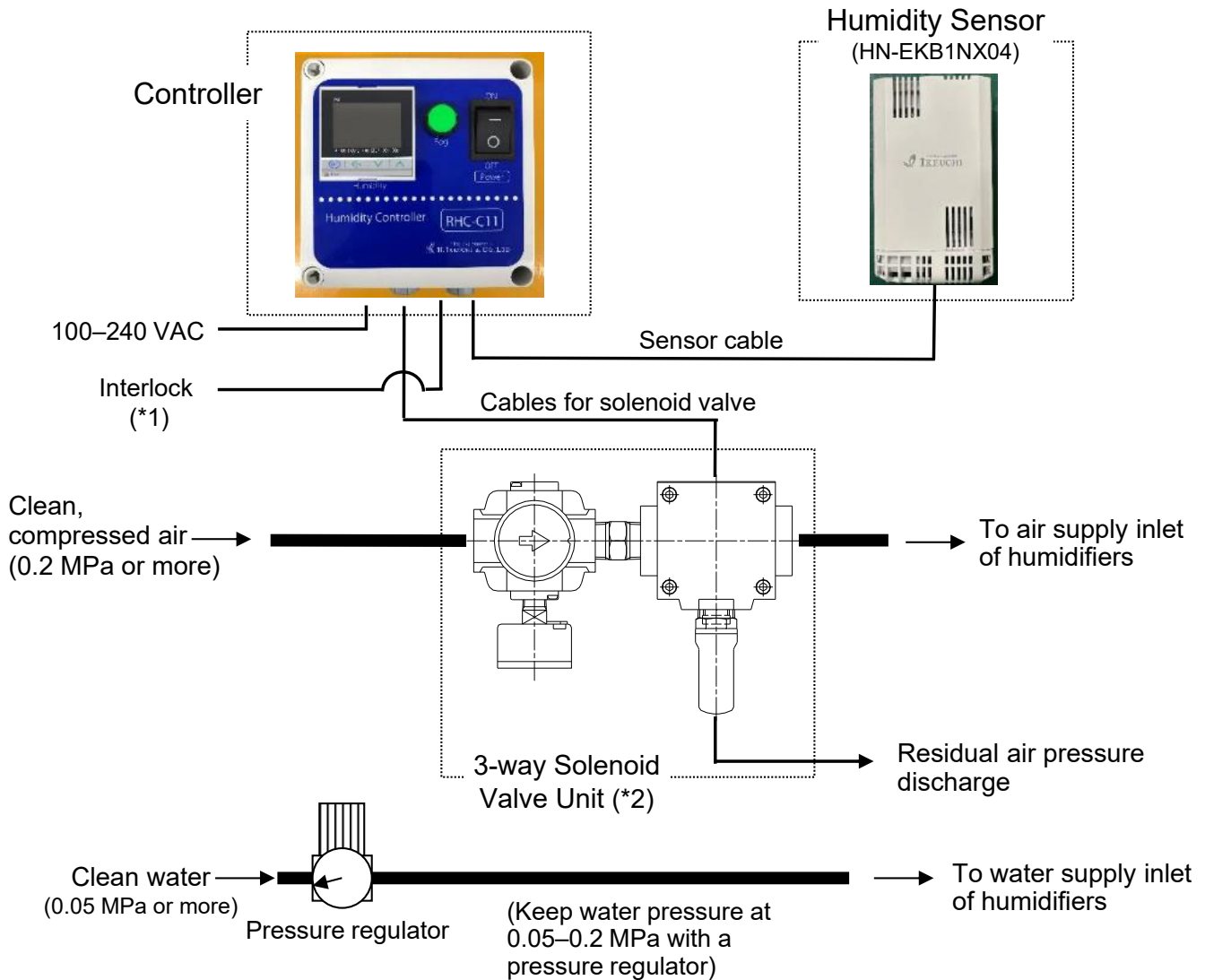

(*1) Interlock

External signal can bring the controller into operation.

(External equipment must have no-voltage normally open contact for connection.)

(*2) 3-way solenoid valve unit

3-way solenoid valve unit functions as follows:

1. Pressure control for compressed air
2. On and off switch for the compressed air supply to the humidifiers.
3. Relieving any remaining air from the pipes after the solenoid valve closes and the compressed air supply stops.

Note:

When the air pressure drops below 0.2 MPa, the 3-way valve will partially open and leak air to the exhaust side and the humidifier nozzle side.

Make sure the air compressor has enough capacity to supply and maintain an air pressure of 0.2 MPa or higher.

● Connection Flow: Case 2 (with 2-way solenoid valve unit)

See page 11 for the wiring diagram.

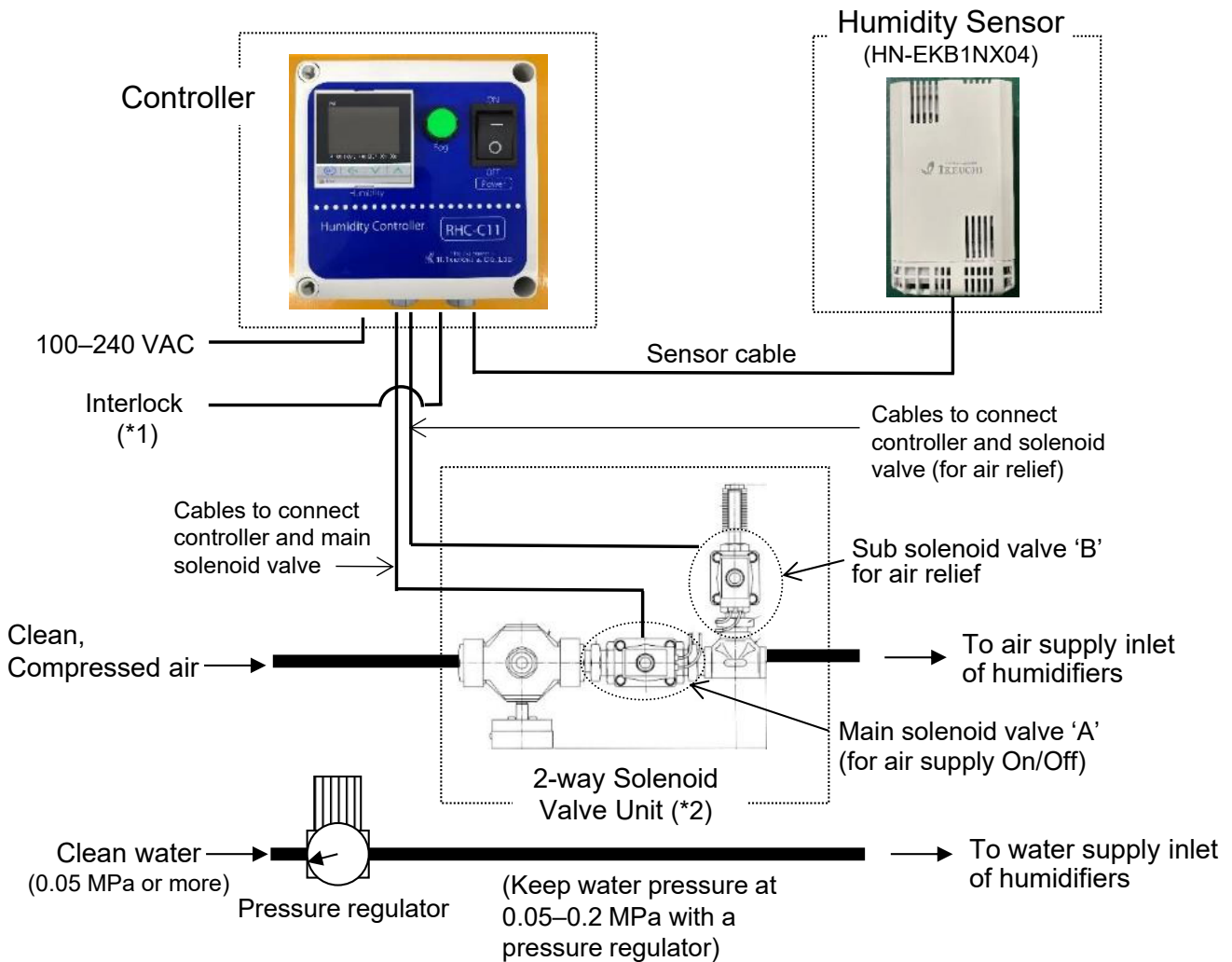

(*1) Interlock

External signal can bring the controller into operation.
(External equipment must have no-voltage normally open contact for connection.)

(*2) 2-way solenoid valve unit

2-way solenoid valve unit functions as follows:

1. Pressure control for compressed air
2. Turning on and off the compressed air supply with a main solenoid valve
3. Air relief solenoid valve relieves remaining compressed air in the pipe immediately when air supply is stopped.

Note:

If using a normally close solenoid valve as the air relief solenoid valve, some of the locked factory settings of the RHC-C11 need to be changed. Please contact us for more details.

● How to Wire: Case 1 (with 3-way solenoid valve unit)

Connect the cables securely to avoid electric shock and short-circuit. Double check to avoid possible wiring errors.

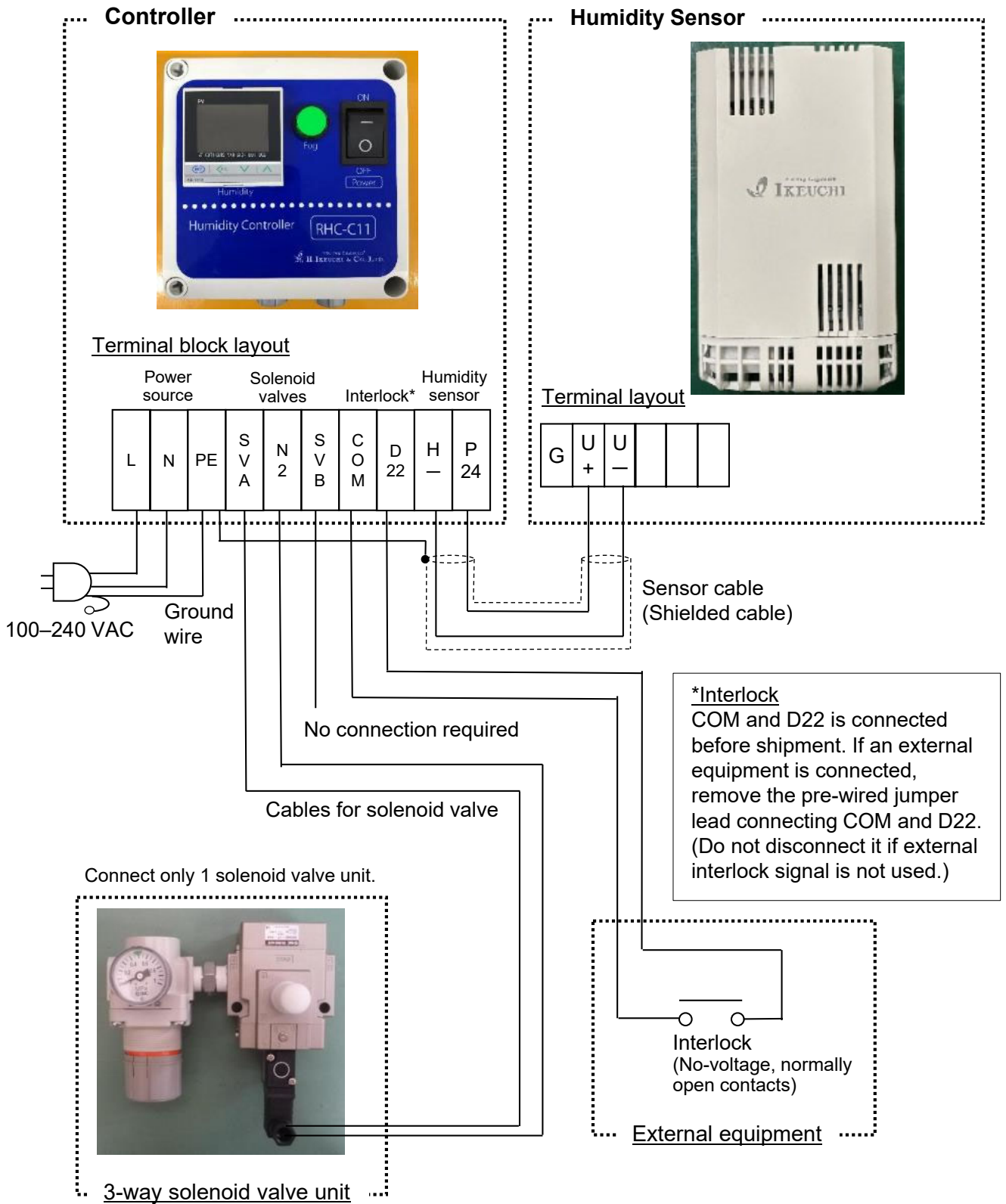

Note: Use a solenoid valve with the same voltage specification as the input voltage.

● How to Wire: Case 2 (with 2-way solenoid valve unit)

Connect the cables securely to avoid electric shock and short-circuit. Double check to avoid possible wiring errors.

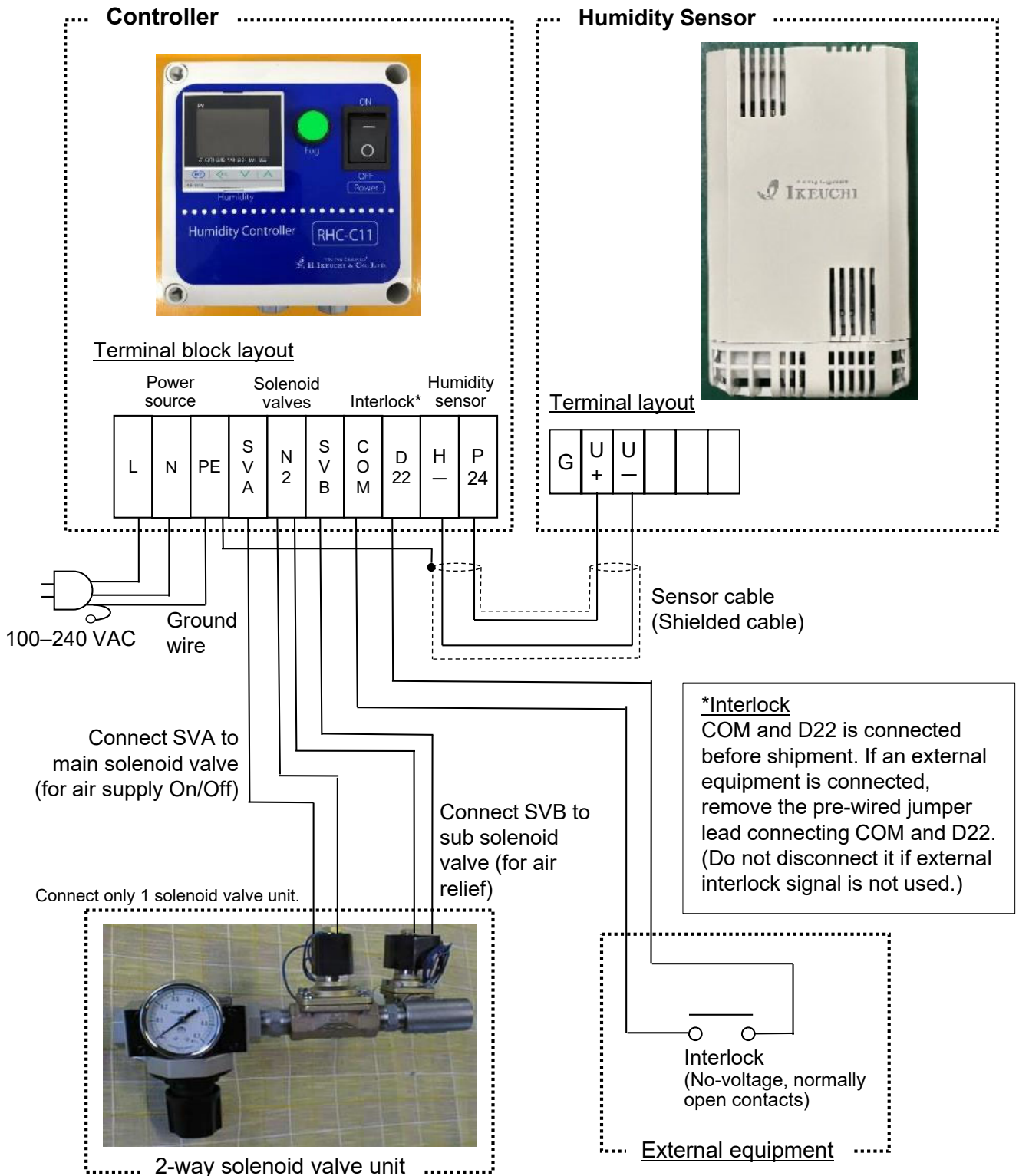

Note: Use a solenoid valve with the same voltage specification as the input voltage.

Avoid running the wires of inductive loads (such as motors and solenoid valves) and sensor cables in parallel or within the same conduit.

9) Wiring at the Sensor

See page 6 (ii) for how to open the sensor cover.

- i. Pass the included sensor cable through the gap between the thermoplate and the humidity sensor body, then pull it out through the wiring entry as shown below.

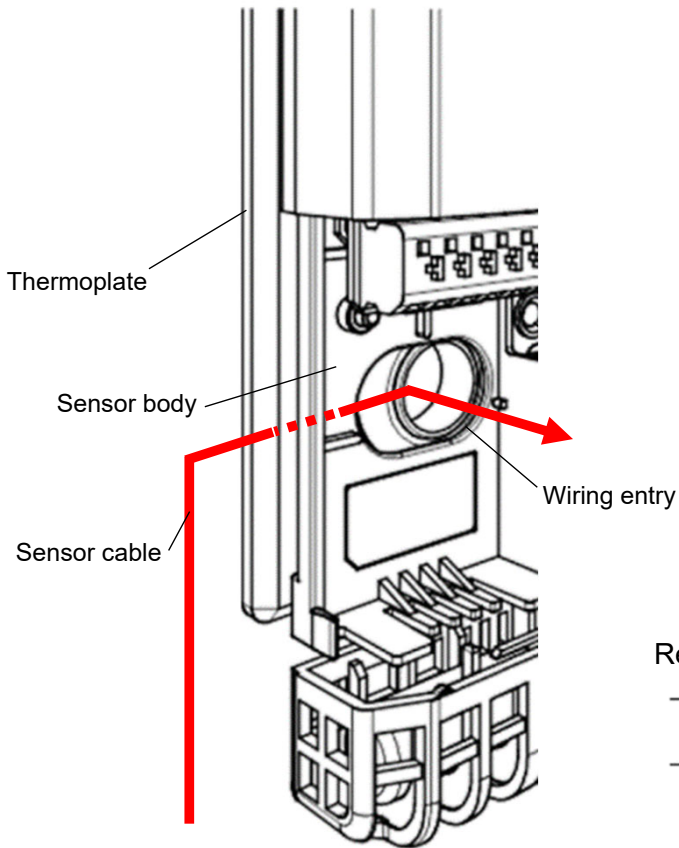

Recommended processing dimensions of sensor cable

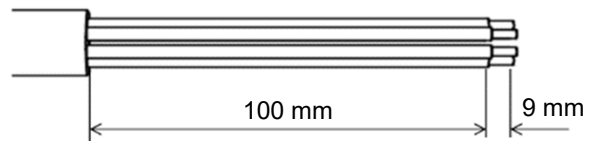

Please use the shielded wire cables.

When using a switch box (not included)

If the thermoplate is mounted on a wall-embedded switch box, pass the sensor cable from the back of the humidity sensor and pull it out through the wiring entry as shown below.

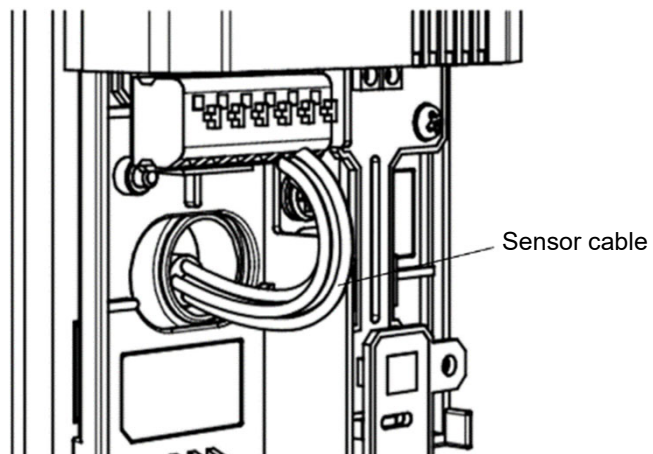

- ii. Connect the sensor cable to the second and third terminal blocks from the left. While pressing down on the protrusion in the upper part of the terminal block, insert the stripped end of the cable into the insertion slot and then release the protrusion.

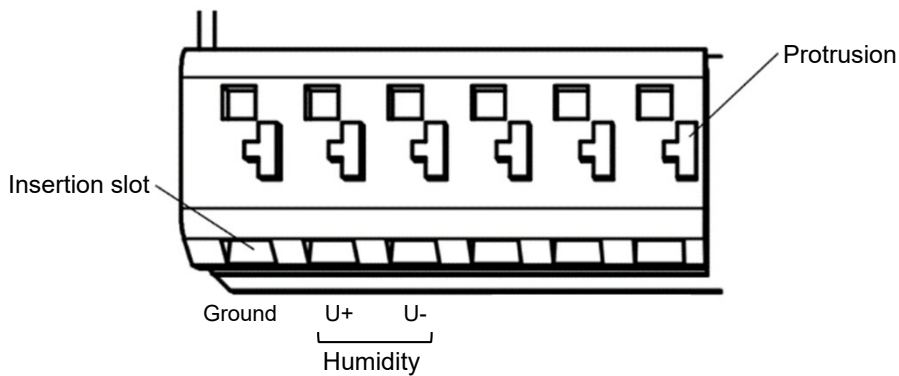

Sensor Cable Wiring:

<u>Controller</u>		<u>Humidity Sensor</u>
P24	↔	U+ (2nd terminal from the left)
H-	↔	U- (3rd terminal from the left)

Note: Do not mistake + for -.

- iii. Slide the humidity sensor cover downwards until it is fully closed. Then, tighten the screw at the top of the cover.

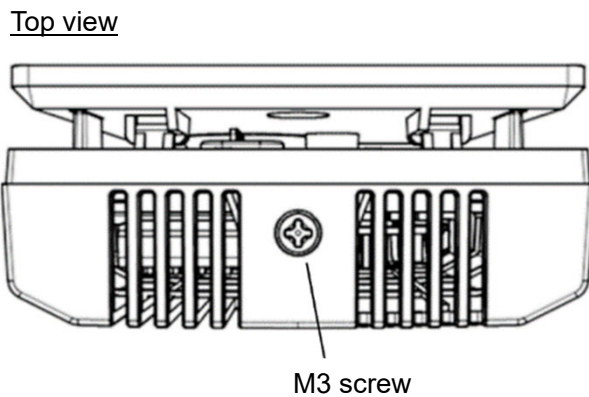

2. Operation

1) How to Use

Be sure to supply clean compressed-air and clean water.

- i. Turn on the power switch. (Keep 20 seconds interval if it is switched on again.)



Caution Do not switch the power on and off in short periods.
The power may not be applied by the safety feature being operated.
When the power is not applied, switch on again after 1 or 2 minutes of switching off.

- ii. Change the humidity set value (SV), referring to How to change the humidity set value (SV) below.
- iii. It starts spraying automatically when the present humidity (PV) < the set humidity (SV).
It stops spraying when the present humidity (PV) > the set humidity (SV).

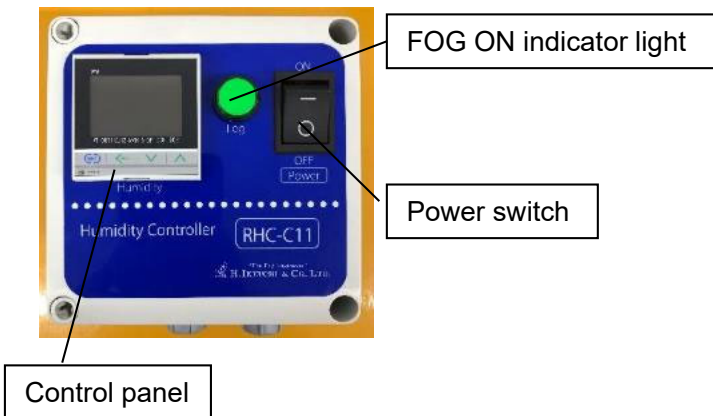

2) How to Change the Humidity Set Value (SV)

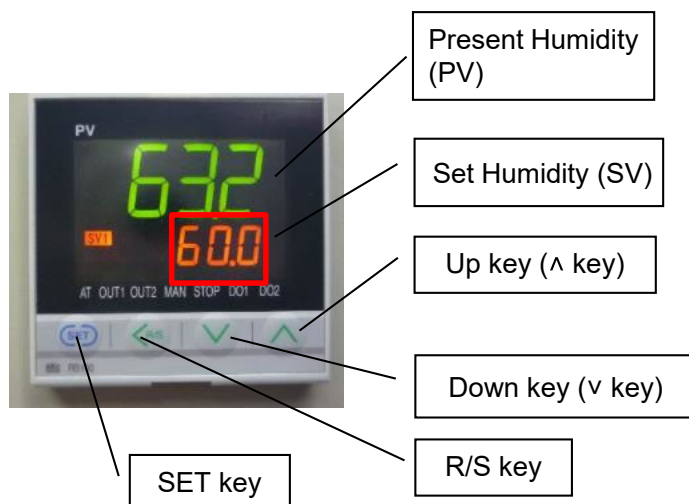

- i. Press the SET key. The rightmost figure of SV is lit and flashes.
- ii. You can increase or decrease the flashing figure with the Up/Down keys.
- iii. You can change the digit with the R/S key. Press the R/S key, then the next left digit flashes. After moving to the leftmost figure, it goes back to the rightmost one.
- iv. When the setting is done, press the SET key to get the display back to original mode.

Note:

Do not change any settings other than the humidity setting.

If you need to change other settings, please contact IKEUCHI or your local sales office.

3. Maintenance

1) Humidity Sensor

i. Maintenance for Humidity Sensor

- When dirty, gently wipe with a dry cloth.
- Periodically inspect the sensor element filter for dirt or clogging.
- The sensor element is a consumable part, so regular replacement is recommended to maintain long-term accuracy and reliability. If there is an abnormal reading in the humidity output, it may indicate that the sensor element has reached the end of its lifespan. In such cases, replacing the sensor element unit will restore normal operation.
The sensor element unit of this product is compatible, so no recalibration is required after replacement. (Replacement part: #423791 Humidity Sensor Element Unit HN-ESKB9NX04)

ii. Replacing the Humidity Sensor Element Unit

Always turn off the power before replacement.

- Remove the screw at the top of the sensor cover, and slide the cover upward to expose the sensor board and main board.
- Hold the sensor board at the holding points (see Fig. 3) and pull it out from the connector on the main board.

Fig. 2

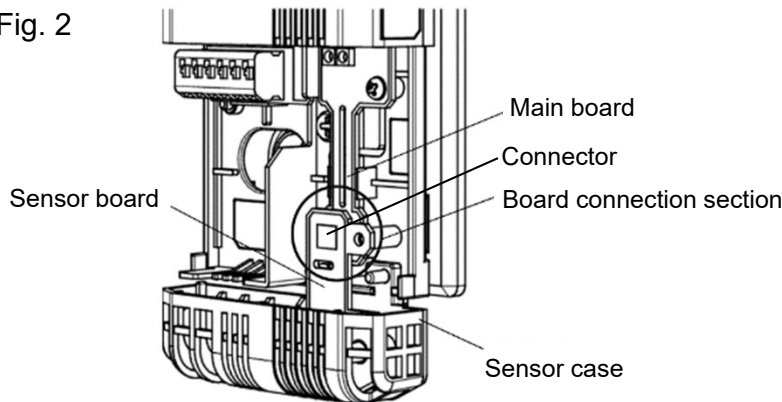

- After confirming the sensor board is detached from the main board's connector, grasp the sensor case and remove it from the main unit by pulling it off the pins.
Note: If you pull out the sensor case before disconnecting the sensor board from the main board, it may result in damage to the main board. Always disconnect the connector first.
- Insert the sensor case of the new sensor element unit into the main unit connection points, and then connect the sensor board to the connector on the main board.

Fig. 3

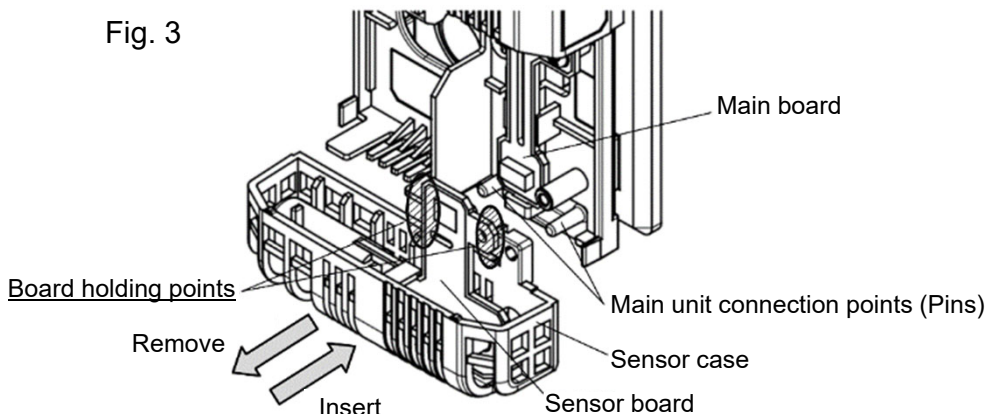

- Slide the humidity sensor cover downwards until it is fully closed. Then, tighten the screw at the top of the cover.

Replacement part for humidity sensor (for sale)

No.	Name	Part No.
1	Humidity Sensor Element Unit	HN-ESKB9NX04 (#423791)

2) Replacing the Fuse Inside the Controller

The fuse is installed for safety precaution against troubles such as short circuit in solenoid valves. If the solenoid valves do not work in the proper manner, it is likely the fuse has blown. Please replace the fuse as shown below.

Caution

Before replacing the fuse, be sure to turn off the circuit breaker. Do work while the unit is NOT connected to a power source.

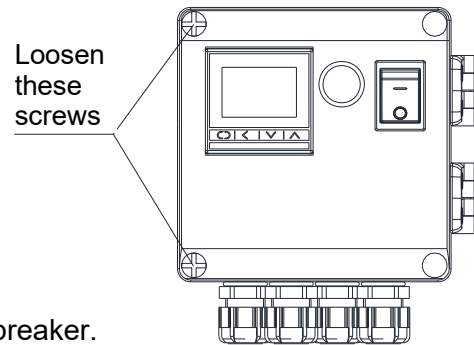

- i. Open the controller cover.
Loosen the 2 screws at the corners to open the cover. (Screws cannot be removed from the cover.)
- ii. Replacing the fuse.
Fuse is installed inside a fuse cover.
Remove the fuse cover by hand, and the fuse comes off together.
Remove the old fuse and replace with a new fuse.
- iii. After replacing the fuse, close the controller cover and tighten the 2 screws firmly.

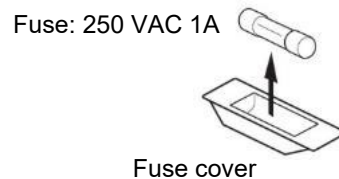
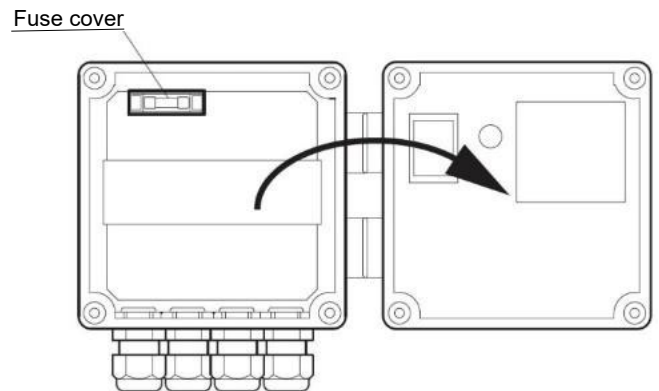

Caution

Use a 250 VAC 1A fuse.

4. Troubleshooting

Check the following points when you have trouble on operation.

No	Troubles	Check points / Probable causes	Solution
1	No display on the control panel.	Fuse has blown.	Replace the fuse (see p.16).
		Switch the power on and off in short periods.	Switch it on again after two minutes of switching off.
2	Present humidity value (PV) on the control panel shows "uuuu" and flashes.	Humidity sensor and controller is unconnected.	Check the wiring for humidity sensor and controller.
3	Accurate humidity is not shown on control panel.	Location of humidity sensor is not appropriate (the place where sensor is located has different humidity and temperature from the other place).	Review the location of sensor (relative humidity is affected by temperature of the place where sensor is located).
		Humidity sensor is dirty, or the sensor element has condensation.	Wipe off dirt with a dry cloth. If condensation is present, allow air to flow through the sensor element and let it dry for at least half a day. Alternatively, replace the sensor element unit with a new one (see p. 15).
		Sensor element is used-up.	Replace the sensor element unit with a new one (see p.15).
4	'FOG ON' light is on, but no spraying occurs.	Compressed air and water are stopped.	Check the pressure gauge and supply compressed air and water.
		No electricity for solenoid valve unit.	Check the wiring for solenoid valve unit and controller.

5. Specifications

●RHC-C11 Humidity Controller

Subject	Specifications	Remark
Voltage	100–240 VAC (50, 60 Hz single phase)	
Power consumption	Approx. 15 W	Excluding solenoid valve.
Operation	Compares present humidity (PV) with set humidity (SV) and automatically starts spraying when $PV < SV$, stops spraying when $PV > SV$.	
Interlock	External signal from normally open contact can bring the controller into operation.	Interlock can be invalid by short circuit the terminals with a jumper wire.
Setting range	0–100% RH	
Allowable temperature and humidity	0–50°C, 0–85% RH	Condensation is never allowed.
Dimensions	(W) 125 x (H) 125 x (D) 100 mm	Excluding protrusions.
Weight	Approx. 700 g	
Material of housing	Polycarbonate (cream color)	IP40

●Humidity Sensor

Subject	Specifications	Remark
Response time	One minute or less	
Dimensions	(W) 85 x (H) 145 x (D) 38 mm	Including the thermoplate, excluding protrusions



“The Fog Engineers”
H. IKEUCHI & CO., LTD.

<https://www.dry-fog.com/en/>

Overseas Division

Fax: +81-6-6538-4022
e-mail: overseas@kirinoikeuchi.co.jp