

**Instruction Manual**

Products: Spray Nozzles

**CTM Series**

Thank you for purchasing this product.  
Prior to use, read this manual carefully and familiarize yourself with the proper operation of the product for best performance.  
H. Ikeuchi & Co., Ltd. takes no responsibility for any accidents and/or injuries resulting from improper handling, installation and/or operation.  
After reading, keep this manual handy for quick reference.  
Please be aware that due to continuing efforts to improve our products, some details in this manual may differ from the actual product.

H. Ikeuchi &amp; Co., Ltd.

## 1. Precautions

### (1) Installation Instructions

- Be sure to flush the pipes before installing the nozzle to remove any dirt and foreign matter.
- Apply sealant or sealing tape to the nozzle or strainer threads.
- Avoid installing the nozzle immediately on or after a bend in the pipe or an elbow. Turbulence may affect the nozzle performance.
- See Table 1 for recommended tightening torque to install the nozzle.

Table 1. Recommended tightening torque

Connection Size		Tightening Torque (N·m)
Nozzle Body (CTMP)	R1/8	8
	R1/4	15
Strainer (CTM)	R3/8	20

### (2) Operation

- Start spraying at a water pressure of 0.05–0.1 MPa to avoid water hammer and then gradually increase to operating pressure.
- After spraying chemical solution, spray clean water for a while to clean the nozzle orifice and the inside of the nozzle.
- To prevent the nozzle from clogging, install filters or use a water treatment system, depending on the water quality.

### (3) Handling Instructions

- Do not damage or scratch the nozzle.
- Do not poke the tungsten carbide orifice with nails, metal pins or other hard objects, which may damage the nozzles.
- Do not apply any strong force, shock or vibration to the nozzle.
- The maximum operating pressure for the CTM Series is 5.0 MPa. To prevent a water hammer, avoid a sudden increase in liquid pressure.
- Store the nozzle in a clean, dust-free place.

## 2. Component of CTM Series

### (1) Components and Materials

#### Nozzle Body (CTMP)

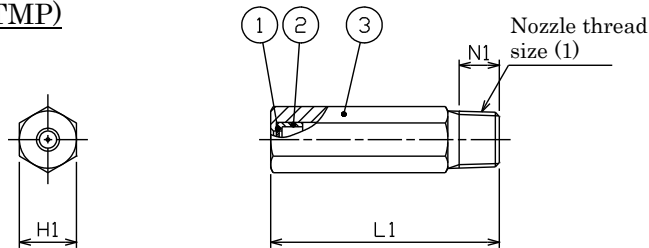

#### Complete Assembly (CTM)

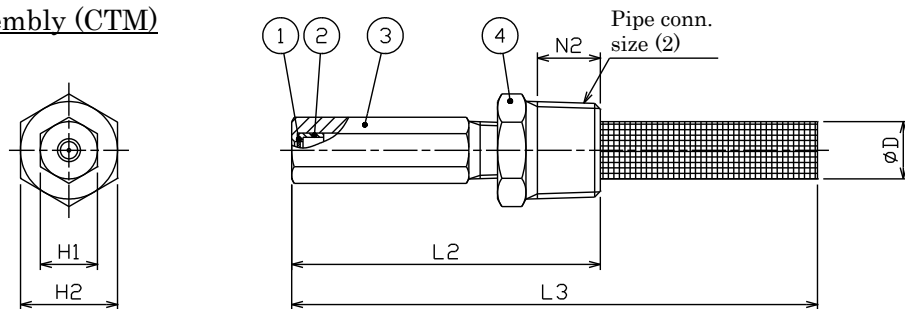

Note: Appearance and dimensions may vary depending on nozzle codes.

No.	Component	Material*	Remarks
1	Orifice	Tungsten carbide	
2	Sleeve	S303	
3	Nozzle Body	S303	
4	Strainer (integrated with adaptor)	S303, S304, and S316	Orifice diameter code: $\phi 0.2$ , $\phi 0.25$ Strainer mesh size: #200
			Orifice diameter code: $\phi 0.3$ , $\phi 0.4$ Strainer mesh size: #150
		S303 and S304	Orifice diameter code: $\phi 0.5$ , $\phi 0.6$ Strainer mesh size: #80
			Orifice diameter code: $\phi 0.7$ to $\phi 1.5$ Strainer mesh size: #50

\*In our material code, "S" represents "stainless steel". For example, S303 stands for stainless steel 303.

### (2) Dimensions

Orifice diameter code	Nozzle thread size (1)	Pipe con. size (2)	Outer dimensions (mm)							
			L1	L2	L3	H1	H2	$\phi D$	N1	N2
$\phi 0.2$ – $\phi 0.9$	R1/8	R3/8	40	54	92	10	17	10	7	11
$\phi 1.0$ – $\phi 1.5$	R1/4	R3/8	40	52	90	14	17	10	10.5	11

### 3. Disassembly

Disassemble the nozzle in a clean, dust-free environment. Always clean the nozzle surface before disassembly to prevent any dust and dirt from entering the nozzle. Be careful not to lose any parts.

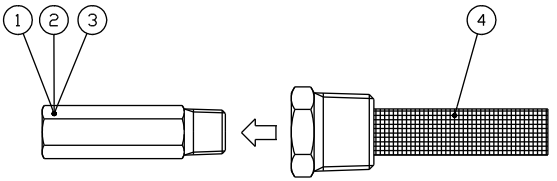
Procedure	Diagram
Remove the nozzle body (part #1-3) from the strainer (#4).	

Appearance and dimensions may vary depending on nozzle codes.

Note:

- After disassembly, purge the inside of the nozzle body and strainer with compressed air.
- Parts #1-3 do not come apart.

### 4. Maintenance

Impurities are most likely to adhere to the orifice of the nozzle tip. Pay special attention to check the condition of this part. Carefully remove any dust and dirt with a brush, toothpick, or bamboo skewer. Clean each part thoroughly from foreign particles to maintain performance.

### 5. Reassembly

Before assembling, apply sealant or sealing tape to the nozzle threads.

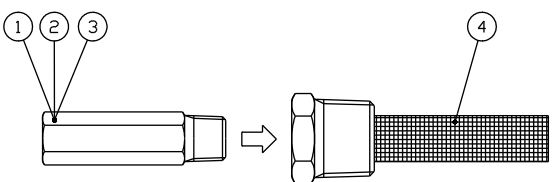
Procedure	Diagram
Screw the nozzle body (#1-3) into the strainer (#4).  Tightening torque for R1/8 nozzle body is 8 N-m. Tightening torque for R1/4 nozzle body is 15 N-m.	

Appearance and dimensions may vary depending on nozzle codes.

## 6. Troubleshooting

If there is a problem, please check the following items first. If the problem persists, please replace the nozzle. (Nozzle body (#1-3) and strainer (#4) can be replaced separately.)

Problem	Possible reason	Solution
Nozzle not spraying or irregular spray pattern	Liquid pressure is too low.	Check the pressure in the pipe and apply the proper pressure.
	Nozzle and/or strainer is clogged.	Clean with ultrasonic cleaner and air blower.
Water leakage	Sealant or sealing tape is damaged or worn.	Replace or change the sealant or sealing tape.
	Nozzles are not screwed in tight enough.	Tighten the nozzles properly with a torque wrench.

## 7. Warranty

There is a one year warranty from the date of our shipment.

Seller shall be responsible for any damage due to design or production and will replace the item free of charge.

Neither this warrant nor any implied warranty applies to damage or harm caused by any or all of the following: 1. Damage due to misapplication and/or misuse, 2. Improper repair and/or modification, 3. Natural disasters, 4. Normal wear-and-tear of consumable parts including clogged nozzles.