

Dry Fog Humidifiers

# AKIMist® "E"

03C, 03B

## Instruction Manual

### CONTENTS

|                                    |      |
|------------------------------------|------|
| ● Introduction                     | p. 1 |
| ● List of Enclosed Items           | p. 2 |
| ● Precautions                      | p. 3 |
| ● Construction and Component Parts | p. 5 |
| ● Before Installation              | p. 7 |
| ● Installation                     | p. 9 |
| ● Operation                        | p.12 |
| ● Maintenance                      | p.13 |
| ● Selecting Ancillary Devices      | p.25 |
| ● Ancillary Devices                | p.27 |
| ● Optional Pipe Connection Kits    | p.29 |
| ● Troubleshooting                  | p.31 |
| ● Maintenance and Inspection       | p.33 |
| ● Specifications                   | p.34 |



"The Fog Engineers"

**H. IKEUCHI & CO., LTD.**

# 1 Introduction

Thank you for purchasing the AKIMist "E" Dry Fog Humidifier.

Please read this Instruction Manual carefully for information about the construction and use of the AKIMist "E" Dry Fog Humidifier in order to ensure optimal performance.

After reading, please keep this manual close to the AKIMist "E" system for easy reference.

AKIMist "E" has two types of nozzles: O3C and O3B (marked on nozzle body). Each type has a different operating pressure range. Confirm the nozzle type mounted on your AKIMist "E" before use.

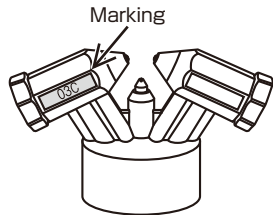

## 2 List of Enclosed Items

★Check that all the items below are enclosed.

### AKIMist®"E"

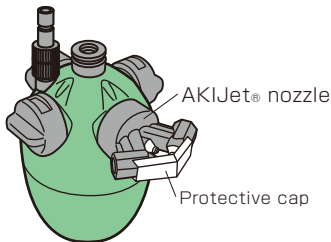

### Liquid Coupler (Socket)



This socket will be included in the optional pipe connection kit if you purchased it.

### Special Cleaning Kit for AKIJet® nozzles

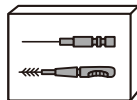

Page 16 shows how to use this cleaning kit. To place an order, use the code #226647 for O3C nozzles and #212837 for O3B nozzles.

- The number of nozzles mounted differs by AKIMist "E" model No.
  - AE-1: Nozzle 1 pc.
  - AE-2: Nozzles 2 pcs.
  - AE-3: Nozzles 3 pcs.
  - AE-4: Nozzles 4 pcs.
- 3 stop plugs are included with each AKIMist "E" unit.
- Protective caps are placed on the nozzles, as well as the air and water inlets of the AKIMist "E" to prevent damage during shipment. Please remove before use.

# 3 Precautions



WARNING

Keep air pressure at 0.2–0.5 MPa (29–73 psi) for **03C** or 0.3–0.35 MPa (44–51 psi) for **03B** and water pressure at 0.05–0.4 MPa (8–58 psi).

AKIMist "E" may detach from pipes under high pressure. Use a pressure regulator to keep the air pressure within the appropriate operating range.

Water may leak under high pressure. Use a pressure regulator to keep the water pressure between 0.05–0.4 MPa. The recommended setting is at approximately 0.1 MPa. (Please see page 34 [Water pressure range](#).)



WARNING

**Never disassemble while air and water valves are open.**

Before disassembling, close both air and water valves. If water valve is open, water will leak. It is dangerous to disassemble while air and water valves are open.



WARNING

**Never use under the following conditions.**

Temperature exceeding 60°C (140°F)  
Direct exposure to sun or rain



WARNING

**Clean AKIMist "E" with soft cloth and neutral detergents.**

Never use a scrubbing brush, polishing powder, lacquer, or thinner.

**NO!** Water Over 0.4 MPa (58 psi)

**NO!** Air Over 0.5 MPa (03C)  
Over 0.35 MPa (03B)



Stop water and air before maintenance!





**Make sure stop plugs ⑦' are properly fixed to the upper body ① and never remove them during operation.**

If the plug ⑦' is loose, air leaks and AKIMist "E" may not function properly. (Note: No Plug ⑦' for AE-4.)



**If one of the AKIJet nozzles is clogged, the other nozzles may not spray properly.**

Clean AKIJet nozzles as shown on pages 15-19.



**Never disassemble AKIMist "E" except for maintenance.**



**Do not remove nozzle protective caps until installation is completed. They protect the nozzle tips during installation.**



# 4 Construction and Component Parts

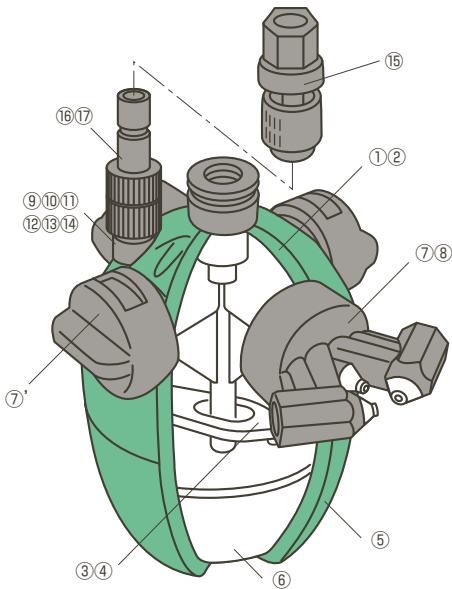

| No. | Description                               | Materials      | Code No.                     |
|-----|---|----------------|------------------------------|
| ①   | Upper Body                                | PP, S303       | #208638<br>[①-④]             |
| ②   | Top Cover                                 | PP             |                              |
| ③   | Valve Lever                               | PP             |                              |
| ④   | Lever Pin                                 | S304           |                              |
| ⑤   | Lower Body                                | PP             | #205890                      |
| ⑥   | Float                                     | PP             | #205888                      |
| ⑦   | AKIJet®03C Nozzle or<br>AKIJet®03B Nozzle | See next page  | 03C: #226214<br>03B: #211507 |
| ⑦'  | Stop Plug                                 | PPS            | #208662                      |
| ⑧   | Packing for Body                          | FKM            | #243353                      |
| ⑨   | Needle Valve                              | S303           | #208642<br>[⑨+⑩]             |
| ⑩   | Valve Seat                                | NBR            |                              |
| ⑪   | Liquid Nipple                             | S303           | #214724                      |
| ⑫   | O-ring                                    | NBR            | #211782                      |
| ⑬   | Strainer Holder                           | S303           | #269608                      |
| ⑭   | Strainer Screen                           | S316           | #17973                       |
| ⑮   | Liquid Coupler (Socket)                   | POM, S304, NBR | #15778                       |
| ⑯   | Liquid Coupler (Plug)                     | S303           | #216627<br>[⑯+⑰]             |
| ⑰   | O-ring                                    | NBR            |                              |

Materials S303/S304/S316's "S" means stainless steel in this manual.

Note: No Stop Plugs are included for AE-4.

## AKIJet® Nozzle Assembly (Part No. ⑦)

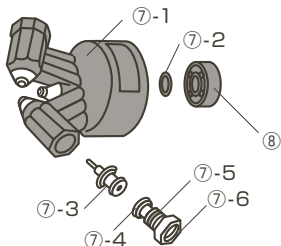

Note: Strainer ⑦-2 is pressed in Nozzle Body ⑦-1 and is not detachable.

| No. | Description      | Materials                      | Code No.                                  |
|-----|------------------|--------------------------------|---|
| ⑦-1 | Nozzle Body      | PPS, OPF-W <sup>®</sup> , S303 | [⑦-1+⑦-2]<br>03C: #226215<br>03B: #211508 |
| ⑦-2 | Air Strainer     | S304, S316                     |   |
| ⑦-3 | Nozzle Tip       | OPF-W <sup>®</sup>             | <b>Nozzle Tip Set</b><br>[⑦-3-⑦-6]        |
| ⑦-4 | Packing          | FKM                            |   |
| ⑦-5 | O-ring           | FKM                            |   |
| ⑦-6 | Hand-screw Plug  | PPS                            | 03C: #246596<br>03B: #246600              |
| ⑧   | Packing for Body | FKM                            | #243353                                   |

\*OPF-W<sup>®</sup> is the registered trademark of Osakazyushi hanbai Co.,Ltd.

Nozzle Tip Set (⑦-3 to ⑦-6) is supplied in sets of 10 pcs.

## Nipple and Valve Assembly (Parts Nos. ⑨-⑭)

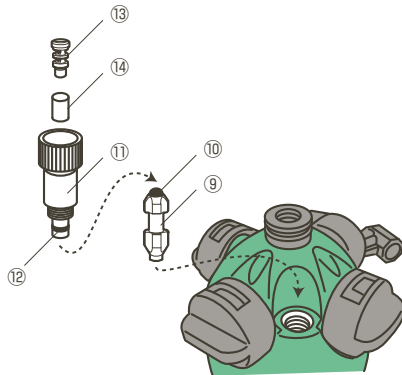

# 5 Before Installation

## ① Ensure there is enough compressed air

AKIMist "E" with one nozzle consumes about 29 L/min, Normal of compressed air. Supply enough compressed air to produce Dry Fog, in order to avoid wetting of floor and machines.



## ② Use stainless-steel pipes

Never use pipes that may rust, or nozzles will clog.

## ③ Use clean air and water

Supply clean air and clean water free of impurities.



Stainless steel pipes

**YES!**



Steel pipes

**NO!**



Hoses

Plastic hoses

**NOT RECOMMENDED**



Make sure there are no loose connections or cracks in pipes and plastic hoses!



#### ④ Select appropriate air pipes

Pipes that are too thin, too long or have too many bents may cause a loss in air pressure and prevent the forming of Dry Fog.

For very long and bent pipes, it is recommended to use pipes one size larger, to make up for a drop in pressure.

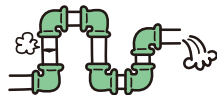

#### ⑤ Keep piping clean

Rust, dirt and debris clog AKIJet nozzles.

Purge all pipes before use.

Purge air pipes with clean water.



#### ⑥ Prevent nozzle freezing

In a cold environment, AKIJet nozzles can freeze because of adiabatic expansion.

Refer to the chart on the right for compressed air and water temperatures to keep the nozzles from freezing when the room temperature is 2°C (36°F). For example: At a room temperature of 2°C (36°F) and a water temperature of 7°C, the temperature of the compressed air will need to be 10°C or higher to prevent the nozzles from freezing.

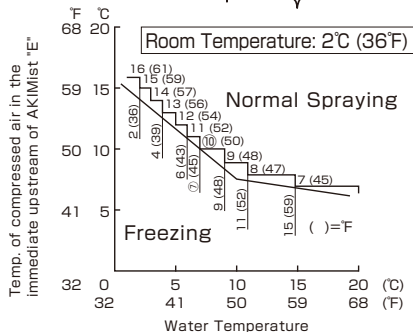

# 6 Installation

## ① For installation

### ! Layout

WARNING

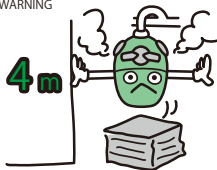

Make sure no wall or pillar is within four meters (13 ft) in front of spraying nozzles. Nothing should be placed under the AKIMist "E".



Install the AKIMist "E" upright.

### ! As main parts are made of plastic, handle AKIMist "E" gently

WARNING



Do not hold the AKIMist "E" in place with the water hose. The AKIMist "E" should be held in place with the air connection.



Avoid screwing too tight.

## ② Air Line (Connect to the air inlet first.)



WARNING

Mounted in the center on the top is the air inlet (1/4").  
If connected wrong, water will leak from the nozzles.

## ③ Water Line



WARNING

The smaller inlet (1/8") is for the water supply.

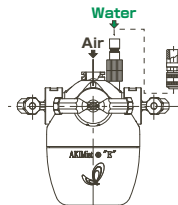

Instructions below show how to assemble a standard pipe connection kit available for purchase from IKEUCHI. For any other pipe connection kits available, see the manual for that kit.

### ② Air Line

Connect in this order

① → ② → ③ → ④ → ⑤ → ⑥.

Make sure to attach the regulator in the correct direction

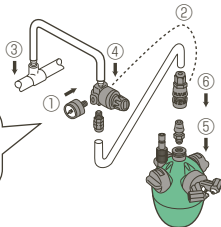

### ③ Water Line

Connect in this order

① → ② → ③.

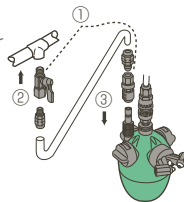

Note:

- Pipe connection kits are optional and available for purchase.
- For details, refer to a separate manual for each pipe connection kit.
- Remove the protective caps from the air and water inlets before installation.

## ④ Operation

- Keep the air pressure between 0.2–0.5 MPa (29–73 psi) for **03C**  
0.3–0.35 MPa (44–51 psi) for **03B**
- Keep the water pressure between 0.05–0.4 MPa (8–58 psi)

Air pressure  
03C → 0.2–0.5 MPa (29–73 psi)  
03B → 0.3–0.35 MPa (44–51 psi)



Water pressure  
0.05–0.4 MPa  
(8–58 psi)



Tap water pressure often increases at night. If the water pressure is over 0.4 MPa, water will leak. Make sure to install a pressure regulator to keep the water pressure below 0.4 MPa (58 psi).

### When you detach the AKIMist "E" for maintenance...

... close the air and water valves...



... disconnect the water hose first...



... then disconnect the air hose.



Note:

Before re-installing, make sure the air and water valves are closed.  
First connect the air hose, then the water hose.

## ⑤ Storing

The AKIMist "E" should be stored in a dry and dust-free location when not in use for extended periods of time. Before storing, drain the water, disassemble the AKIMist "E" and clean the nozzles, then put it back together.



# 7 Operation

## ★Inspect equipment periodically!

Perform maintenance on the compressor and air/water purification equipment according to their instruction manual.



## ★Quick spray ON/OFF

Install a solenoid valve immediately before the AKIMist "E" for quick ON/OFF.

In case a solenoid valve cannot be installed near the AKIMist "E", install an air relief circuit.

\*See page 25 ⑨ Selecting Ancillary Devices for an air relief circuit.



## ★Automatic humidity control!

Install a humidity controller, which maintains the required humidity automatically.

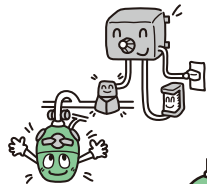

## ★Aim Dry Fog at specific area where humidity needs to be raised!

The AE-UT adapter, available for purchase separately, allows for the spray direction to be adjusted as needed, both horizontally and vertically. It can easily be attached and removed by hand.

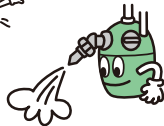

# 8 Maintenance



WARNING

For safety, close both air and water valves before any maintenance.

- ★ Disconnect the AKIMist "E" from the pipes to perform maintenance in a safe place.



- ★ Tools required for maintenance

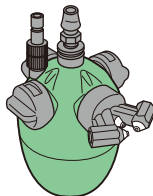

AKIMist "E"



Flat-head screwdriver



Soft cloth



Neutral detergent

## ① Disassembling AKIMist "E"

- ① Close the air pressure regulator to stop the air.
- ② Close the valve to stop the water.
- ③ Disconnect the water coupler by pushing the sleeve down.
- ④ Disconnect the air coupler by pulling the sleeve up.
- ⑤ Turn the lower portion of body (lower body) clockwise.
- ⑥ Pull down the lower body.

Note:

- For details of connecting/disconnecting the air and water couplers, please refer to the pipe connection kit manual.
- Be careful as the lower body contains water.

<Assembling> Reverse the disassembly procedure.

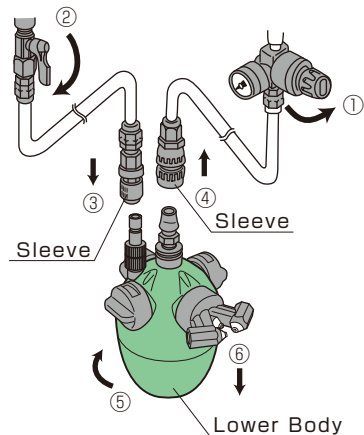

## ② Cleaning AKIJet with Enclosed Cleaning Kit

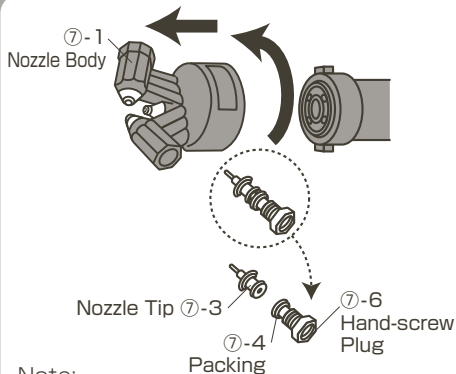

<How to disassemble an AKIJet nozzle>

- ① Turn the nozzle body ⑦-1 counterclockwise to detach the nozzle assembly.
- ② Turn the hand-screw plug ⑦-6 counterclockwise to remove it. The nozzle tip ⑦-3 will be removed at the same time.
- ③ Pull the nozzle tip ⑦-3 off the hand-screw plug ⑦-6 by hand.

Note:

- Be careful not to lose the small parts.
- **The plastic nozzle tip is fragile and must be handled with care.**  
Never hit the top of the nozzle tip with a hard object or on a hard surface.
- Never remove the packing ⑦-4 from the hand-screw plug ⑦-6, it is impossible to reassemble.



Here is a quick video on cleaning of AKIMist nozzles. →



If the problem persists after cleaning, replace the nozzle or nozzle tip set. See page 6.

Open the cleaning kit and take out the needle and brush after step ①.

①



Gently wipe the nozzle tip with a cloth moistened with neutral detergent.

The nozzle tip, especially the extreme tip and orifice, is the most delicate part. Rough handling can damage the plastic tip and harm the nozzle performance.

②

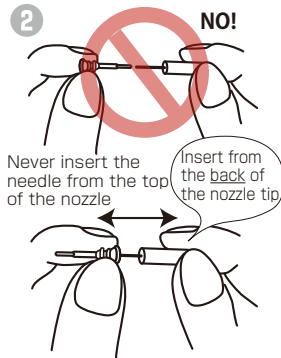

Always push the needle through from the back of the nozzle tip to remove dirt and debris, then purge with compressed air.

③

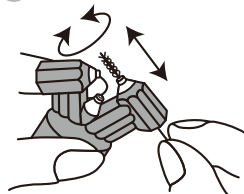

Insert the brush into the nozzle body as shown, twist it inside and push in and out several times to remove dirt and debris. Then, purge with compressed air.

If dirt and debris are hard to remove, wet the brush with neutral detergent and repeat the process.

4

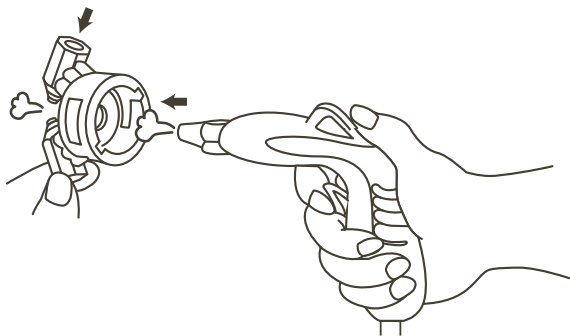

Purge the middle hole and the nozzle tip insertion area with compressed air.

### <How to assemble AKIJet nozzle>

First attach the nozzle tip ⑦-3 to the plug ⑦-6, and screw them into the nozzle body ⑦-1.

For **03C** nozzles, make sure the two notches of the nozzle tip slide over the guides inside the nozzle body, then screw it in.

If the nozzle tip does not fit, stop twisting, reassemble and try again.

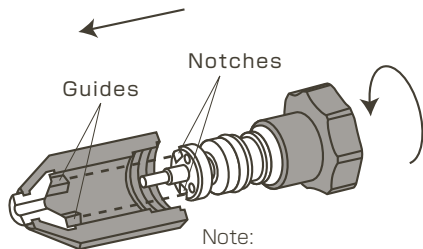

Note:  
03B nozzles do not have notches or guides.

### CAUTION

- The nozzle tip is made of very thin plastic. Be careful not to hit it on a hard object or surface.
- If there seems to be resistance or something inside the nozzle body, stop screwing, pull out the nozzle tip, and clean the nozzle body again. Do not force the nozzle tip in.
- Do not use a broken or damaged nozzle tip, this will cause coarse atomization and water leakage.

### ③ Cleaning Air Strainer

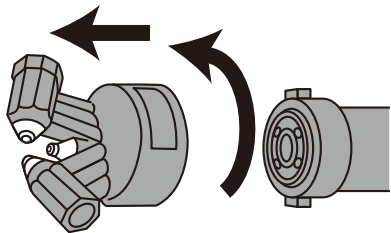

① Twist AKIJet nozzle counterclockwise to detach it from the adaptor.

② To clean the air strainer ⑦-2 in the nozzle, wipe off dust with a soft cloth.

Note:

The air strainer ⑦-2 is fixed inside the nozzle body ⑦-1 and is NOT detachable.

<How to connect the nozzle to the adaptor>

Fit the grooves of the nozzle over the guides of the adaptor, push the nozzle down, and then twist it clockwise until tight.

## ④ Component Service Life

| Components           |     | Code No. | Estimated Service Life |
|----------------------|-----|----------|------------------------|
| Packing for Nozzle   | ⑦-4 | #208659  | Two years              |
| O-ring for Nozzle    | ⑦-5 |          |                        |
| Hand-screw Plug      | ⑦-6 |          |                        |
| FKM Packing for Body | ⑧   | #243353  | Five years             |

Note:

- Service life varies depending on operational conditions.
- It is recommended to replace parts ahead of the end of service life.
- Parts ⑦-4, ⑦-5, and ⑦-6 are sold as one component (Code #208659).

## ⑤ Cleaning Water Strainer

AKIMist "E" has a water strainer installed in the liquid nipple.

### ① Remove Liquid Nipple.

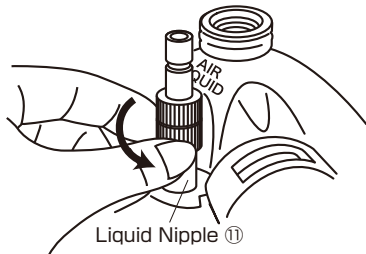

Hold the humidifier body firmly and turn the liquid nipple ⑪ counterclockwise to remove. The liquid nipple ⑪ will come off with the liquid coupler ⑫ attached.

### ② Remove Liquid Coupler.

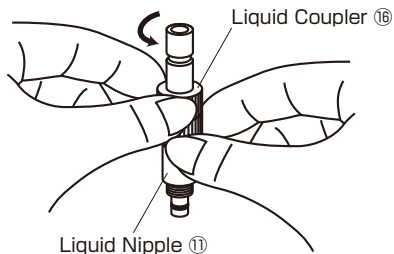

Hold the liquid nipple ⑪ and turn the liquid coupler ⑫ counterclockwise to remove.

3 Remove Strainer.



With a flat-head screwdriver unscrew the strainer from inside the liquid nipple.

- \*Outside of strainer screen may be dirty.
- \*Be careful not to lose strainer.

4 Clean Strainer Screen.

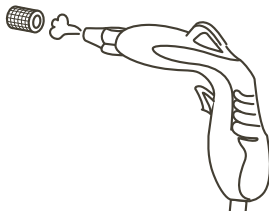

Purge the strainer screen ⑭ with compressed air or wash with water until clean.

## ⑥ Cleaning Liquid Nipple and Needle Valve

The needle valve is located under the liquid nipple, inside the upper body of the humidifier.

### ① Cleaning Liquid Nipple



Remove any dirt on the thread of the liquid nipple with a tooth-pick and/or compressed air.



Wipe the top part of the liquid nipple, which is in contact with the needle valve, with a soft cloth and purge with compressed air.

### ② Cleaning Needle Valve

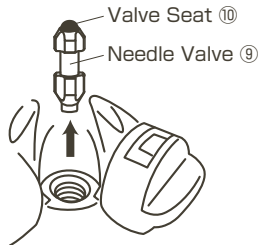

Remove the needle valve, with the valve seat, from the humidifier body for cleaning. Wash with water or wipe with a soft cloth, then purge with compressed air.



## ⑦ Reassembling Water Strainer and Needle Valve

Insert the needle valve, with the valve seat, into the upper body of the humidifier and reverse the disassembly instructions on pages 21 and 22.

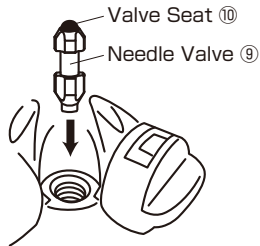

Use caution with the needle valve orientation when inserting as shown above.

# 9 Selecting Ancillary Devices

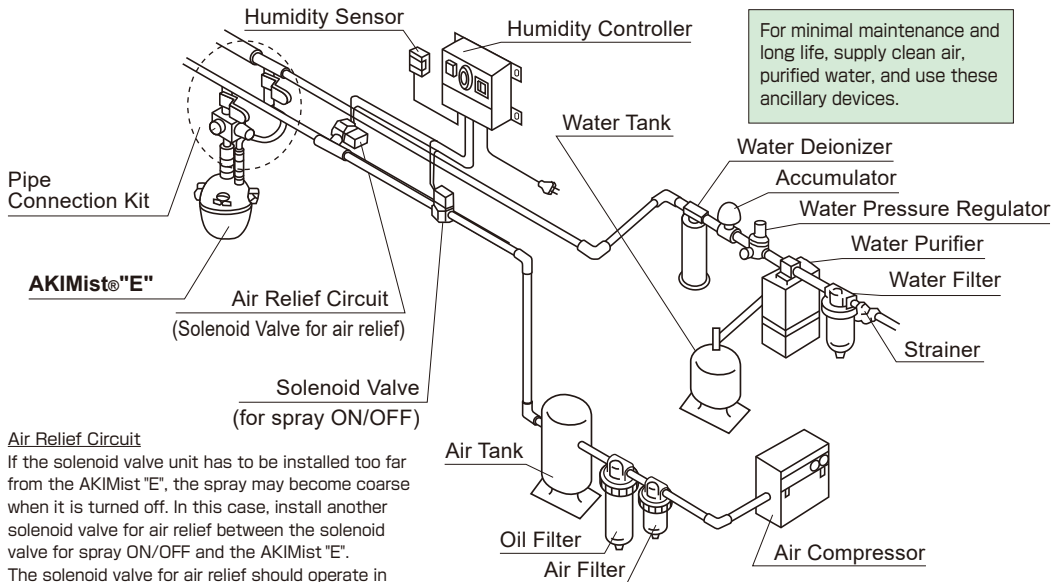

## Air Relief Circuit

If the solenoid valve unit has to be installed too far from the AKIMist "E", the spray may become coarse when it is turned off. In this case, install another solenoid valve for air relief between the solenoid valve for spray ON/OFF and the AKIMist "E".

The solenoid valve for air relief should operate in reverse to the spray-ON/OFF solenoid valve.

|                                 |  |   |
|---------------------------------|--|---|
| ☆For easy installation          | <p>Pipe Connection Kits</p> <p>We have two types of connection kits: Hanging down type that comes with or without a plate; and Wall mounting type.</p>   | Please see pages 29 and 30.   |
| ☆Must be installed              | <ul style="list-style-type: none"> <li>• Air Compressor</li> <li>• Air Filter (Filtration: 0.3 <math>\mu\text{m}</math>)</li> <li>• Oil Filter (Filtration: 0.3 <math>\mu\text{m}</math>)</li> <li>• Air Tank</li> <li>• Water Strainer (150 mesh)</li> <li>• Water Filter (Filtration: 5 <math>\mu\text{m}</math>)</li> <li>• Water Pressure Regulator</li> </ul> | <p>For supply of clean compressed air.</p> <p>For removal of foreign particles from compressed air.</p> <p>For removal of oil mist, dust and moisture contents from compressed air.</p> <p>For stable air supply.</p> <p>For removal of foreign particles from water.</p> <p>For water filtration.</p> <p>For control of proper water pressure.</p> |
| ☆For easier maintenance         | <ul style="list-style-type: none"> <li>• RO Water Purifier</li> </ul>  | For removal of calcium, magnesium and silica from water.  |
| ☆For high grade purified water  | <ul style="list-style-type: none"> <li>• Water Deionizer (using ion-exchange resin)</li> </ul>   | For high grade purified water in clean room.  |
| ☆For automatic humidity control | <ul style="list-style-type: none"> <li>• Humidity Controller</li> <li>• Solenoid Valve Unit</li> </ul>   | For maintaining desired relative humidity.  |

# 10 Ancillary Devices

## Humidity Controller • Maintain desired humidity any time, day or night.

### [Compact Digital Type]



(RHC-C11)

- Digital display of present humidity and target humidity.
- Compact size to fit anywhere.
- Includes a humidity sensor.
- Accuracy:  $\pm 3\%$
- Voltage: 100-240 VAC

### [Digital Type]



(RHC-D)

- Digital display of present humidity and target humidity.
- A single controller can control up to four zones spread over a wide area individually.
- Accuracy:  $\pm 3\%$
- Voltage: 100-110 VAC or 200-220 VAC

## Humidity Sensor



- For sensing humidity and transmitting a signal to the controller.

## Solenoid Valve Unit

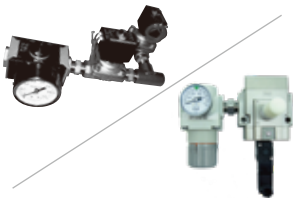

- A solenoid valve and reducing valve are bundled together as a unit. For automatic on-off control of air and water, use with humidity controller.

## Water Filter



- For removal of foreign particles over  $5 \mu\text{m}$ .
- Available in a variety of sizes

## Air Filter



- For removal of moisture contents and dust over 0.3  $\mu\text{m}$  from compressed air to make air clean.
- Available in a variety of sizes

## Oil Filter



- For removal of oil mist, dust and moisture contents over 0.3  $\mu\text{m}$  from compressed air with micro-fiber.
- Filter element must be replaced if differential pressure increases to 0.1 MPa.
- Available in a variety of sizes

## Water Pressure Regulator



- For control of water pressure.  
Set pressure: 0.01-0.2 MPa

## Water Strainer



- For removal of foreign particles over 0.1 mm from water.  
(Mesh size 150)

# 11 Optional Pipe Connection Kits for Easy Installation

Hanging-down (NP) Kit without plate

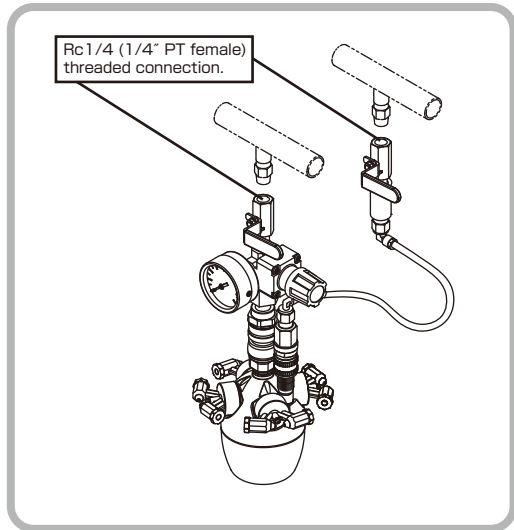

Hanging-down Kit

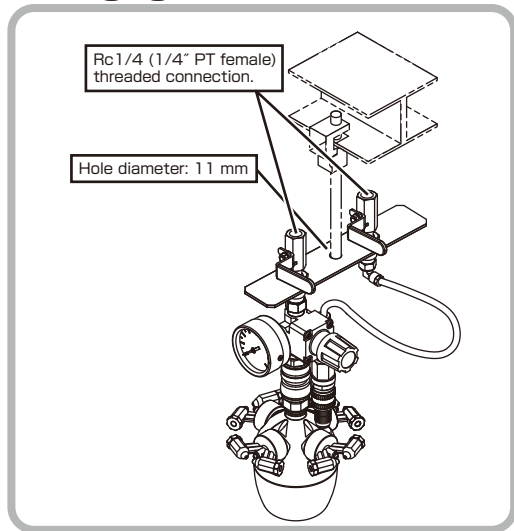

## □ Wall Mounting Kit

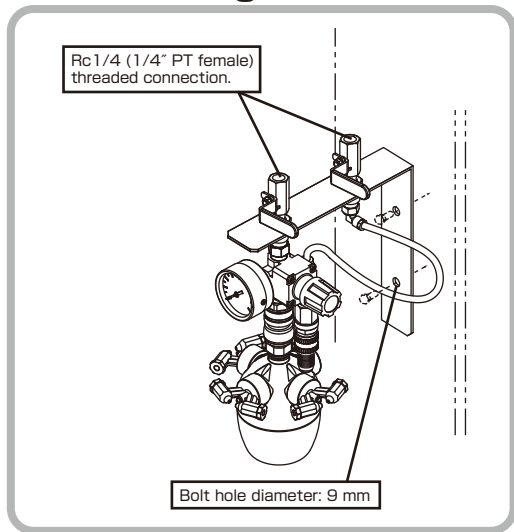

# 12 Troubleshooting

Video for No/Abnormal Spraying Troubleshooting



If you have trouble, stop air and water supply and check the following.

| Troubles   | Probable Causes  | Solutions  |
|--|--|--|
| 1. No spray or stops spraying after a short time | 1) Air pressure is too low.                                      | Set air pressure to 0.2-0.5 MPa (29-73 psi) for 03C or 0.3-0.35 MPa (44-51 psi) for 03B. |
|  | 2) Stop plug ⑦' is loose.  | Tighten stop plug ⑦' properly.   |
|  | 3) Pressure regulator is not functioning properly.               | Check flow direction of pressure regulator.  |
|  | 4) Solenoid valve is not functioning properly.                   | Check power source, wiring, and flow direction of solenoid valve or replace.             |
|  | 5) Strainer in liquid nipple is clogged.                         | Clean strainer screen ⑭ (See p.21-22).   |
| 2. Irregular or intermittent spray               | 6) Packing ⑦-4 inside the nozzle is improperly seated.           | Replace a set of Part# ⑦-4-⑦-6 (CODE #208659) (see p.6, 15-18, 20).                      |
|  | 7) Nozzle is clogged.  | Clean nozzle (see p.15-18).  |
|  | 8) Packing between nozzle and adaptor is improperly set or worn. | Set packing ⑧ properly or replace.   |
|  | 9) Nozzle orifice is frozen.                                     | Install air heating equipment.   |
| 3. Liquid dripping from nozzle orifice           | 1) Dust around the nozzle orifice.                               | Clean the nozzle orifice (see p.15-18).  |
|  | 2) Liquid pressure is too high.                                  | Reduce liquid pressure below 0.4 MPa [58 psi] (see p.11).                                |
|  | 3) Nozzle tip is deformed.                                       | Replace nozzle tip set (see p.6, 15, 18).  |
|  | 4) Solenoid valve is not installed near AKIMist "E".             | Install solenoid valve immediately before AKIMist "E", or install an air relief circuit. |



Video for Water Leakage Troubleshooting



| Troubles   | Probable Causes   | Solutions  |
|--|---|--|
| 4. Spray is coarse                               | 1) Air and liquid connection is reversed.                       | Connect correctly (see p.10).  |
|  | 2) Stop plug ⑦ is loose.  | Tighten stop plug ⑦ properly.  |
|  | 3) Air piping is inadequate, twisted or throttled.              | Make sure the pipe size is correct, and that there are no twists or throttles (see p.8). |
|  | 4) Air pressure is too low.                                     | Set air pressure to 0.2-0.5 MPa (29-73 psi) for O3C or 0.3-0.35 MPa (44-51 psi) for O3B. |
|  | 5) Air filter on air pipe is clogged.                           | Clean or replace air filter.   |
|  | 6) Air strainer ⑦-2 is clogged.                                 | Clean or replace air strainer (see p.19).  |
|  | 7) Solenoid valve is clogged.                                   | Clean or replace solenoid valve.   |
|  | 8) Nozzle tip is deformed.                                      | Replace nozzle tip set (see p.6, 15, 18).  |
| 5. Coarse spray or liquid dripping when stopping | 1) Solenoid valve is not installed near AKIMist "E".            | Install solenoid valve immediately before AKIMist "E", or install an air relief circuit. |
| 6. Liquid dripping from humidifier body          | 1) Liquid pressure is too high.                                 | Reduce liquid pressure below 0.4 MPa [58 psi] (see p.11).                                |
|  | 2) Needle valve ⑨, with valve seat ⑩, not functioning properly. | Make sure the needle valve is set properly, or replace it (see p.24).                    |
|  | 3) Liquid nipple ⑪ is loose.                                    | Tighten liquid nipple properly.  |
|  | 4) O-ring ⑦-5 in inside nozzle is improperly set or worn.       | Replace nozzle tip set (see p.6, 15, 18).  |

If the above solutions do not work, please contact your local distributor.

# 13 Maintenance and Inspection

Maintain all equipment according to their instruction manuals.

| Inspection Cycle | Inspection Item                              | Content  |
|------------------|--|--|
| Daily            | 1) Air pressure gauge                        | Confirm that air pressure is 0.2-0.5 MPa (29-73 psi) for O3C or 0.3-0.35 MPa (44-51 psi) for O3B when spraying.                |
|                  | 2) Air filter                                | Check drain water volume and confirm it is within upper limit.   |
|                  | 3) Solenoid valve                            | Confirm that ON/OFF control of solenoid valve is working correctly. Also check humidity controller operation at the same time. |
| Periodical       | 1) Elements of air filter and oil filter     | Clean with neutral detergent once a month.   |
|                  | 2) Element of water strainer                 | Clean with water and purge with compressed air once a month.   |
| Off-season       | 1) Purge compressed air and water from pipes | Air and water must be purged at end of usage season.   |
|                  | 2) Elements of air filter and water strainer | Before and after use, wash and purge them with compressed air. Check there is no rust before use.                              |
|                  | 3) Purge all pipes                           | Before and after use, purge them with compressed air.  |

## ★Consumable Parts

| Components                            | Estimated service life |
|---------------------------------------|------------------------|
| Elements of air filter and oil filter | Two (2) years          |
| Element of water strainer             | Four (4) years         |
| Diaphragm of pressure regulator       | Two (2) years          |
| Plunger of solenoid valve             | Five (5) years         |

# 14 Specifications

\*at air pressure of 0.3 MPa

| Model No.                   |                      | AE-1                     |               | AE-2                     |               | AE-3          |               | AE-4          |                |
|-----------------------------|----------------------|--------------------------|---------------|--------------------------|---------------|---------------|---------------|---------------|----------------|
| (Nozzle type)               | Unit                 | (03C)                    | (03B)         | (03C)                    | (03B)         | (03C)         | (03B)         | (03C)         | (03B)          |
| Number of nozzle(s) mounted | piece                | 1                        |               | 2                        |               | 3             |               | 4             |                |
| Dimensions [width x height] | mm (")               | 109 × 110<br>(4.3 × 4.3) |               | 125 × 110<br>(5.0 × 4.3) |               |               |               |               |                |
| Weight                      | Net                  | 290 (0.64)               |               | 300 (0.66)               |               | 310 (0.68)    |               | 320 (0.71)    |                |
|                             | Loaded               | 310 (0.68)               |               | 320 (0.71)               |               | 330 (0.73)    |               | 340 (0.75)    |                |
| Spray volume*               | L/hr (GPH)           | 2.4<br>(0.63)            | 3.3<br>(0.87) | 4.8<br>(1.27)            | 6.6<br>(1.74) | 7.2<br>(1.90) | 9.9<br>(2.61) | 9.6<br>(2.54) | 13.2<br>(3.48) |
| Air consumption*            | L/min, Normal (SCFM) | 29 (1.08)                |               | 58 (2.16)                |               | 87 (3.24)     |               | 116 (4.32)    |                |
| Air compressor motor power  | kW [per unit]        | 0.4                      |               | 0.75                     |               | 1.5           |               |               |                |

Max. of 4 AKIJet nozzles can be mounted on one AKIMist "E".

## Air Pressure Range

03C → 0.2–0.5 MPa (29–73 psi)  
 03B → 0.3–0.35 MPa (44–51 psi)

- Humidifier's required air pressure. Please use within given pressure range. Exceeding pressure range causes water leaks and coarse, irregular spray.

## Water Pressure Range

0.05–0.4 MPa (8–58 psi)

- Humidifier's required water pressure. Please use within given pressure range. Exceeding pressure range causes water leaks and irregular spray.
- Even when set within the given range, supply water pressure may exceed this range due to water and operating conditions. The recommended setting is about 0.1 MPa (15 psi).



いけうち

“The Fog Engineers”

**H. IKEUCHI & CO., LTD.**

Daiichi Kyogyo Bldg. 1-15-15, Awaza Nishi-ku  
Osaka 550-0011, Japan

TEL: (81)-6-6538-4015 FAX: (81)-6-6538-4022

E-mail: [overseas@kirinoikeuchi.co.jp](mailto:overseas@kirinoikeuchi.co.jp)

Global Network:

<https://www.dry-fog.com/en/corporate/globalnetwork/>