



Patented

Non-wetting

Dry Fog Humidifiers AKIMist® "E"

Compact, efficient, energy-saving humidifiers



AE-4



AE-1



AE-2



AE-3

IKEUCHI's Atomization Technology

1

What is Dry Fog?

Dry Fog is ultra-fine "non-wetting" fog, which doesn't wet the objects it touches. AKIMist "E" produces a large amount of Dry Fog.

2

Why is Dry Fog non-wetting?

Small droplets rebound from an object, but large droplets burst and wet the object.

Dry Fog droplets are so fine that they do not burst or wet the objects it touches.

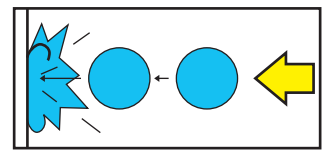

Large droplets

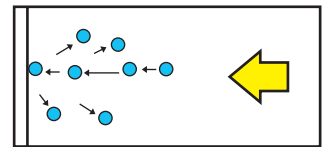

Dry Fog, fine fog droplets

3

How our Dry Fog is produced

Atomized droplets, sprayed out from the two orifices apart, collide with each other in the center. Simultaneously they generate ultrasonic waves of 33–40 kHz to further atomize the droplets and homogenize their size.

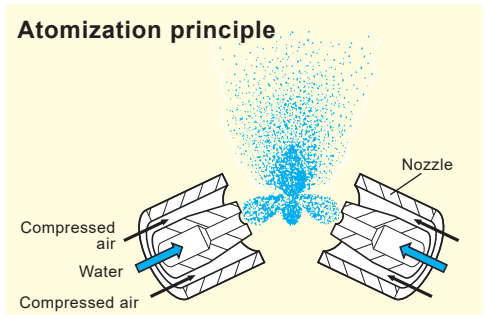

AKIMist "E" Product Page
(with links to videos and case studies)



AKIMist "E" Spray Demo



AKIMist "E" 3D/2D CAD Models

CONTENTS

IKEUCHI's Atomization Technology.....	1
AKIMist "E" Specifications.....	3
Optional/Related Products.....	5
▶ AE-UT Adaptor.....	5
▶ Pipe Connection Kits.....	5
▶ AKIMist "E" TN.....	6
▶ AE-KIT.....	6
▶ AE-T set.....	6
Installation & Ancillary Devices.....	7
Benefit of Humidification.....	9
Customer Case Studies.....	10
Spray Droplets Size by Various Humidifiers.....	Back cover

AKIMist "E" Installation Example in Many Industries



AKIMist® "E" Dry Fog Humidifiers

Compact, efficient, energy-saving humidifiers create quality fog with low air consumption!

Dimensions

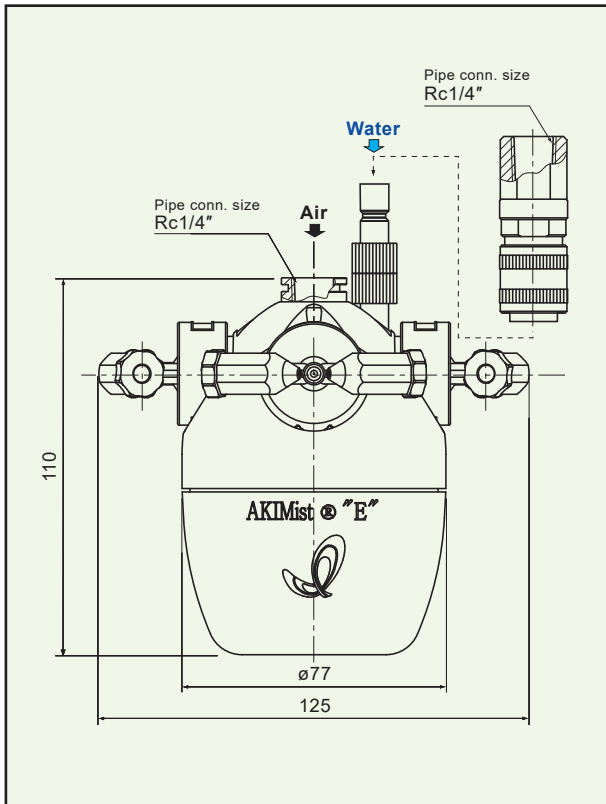

Materials

- Body: PP, Stainless steel 303
- Nozzle: Stainless steel 303, PPS
- Nozzle tip: Plastic
- Other parts: NBR, FKM (O-ring, Packing)

Weight

- Approx. 340 g (with four nozzles and filled with water)

Note:

- Before disassembly, close the water valve to prevent water leakage.
- Handle AKIMist with care as its main parts are made of plastic and delicate.
- Stop plugs (PPS) are enclosed to reduce the number of nozzles used.

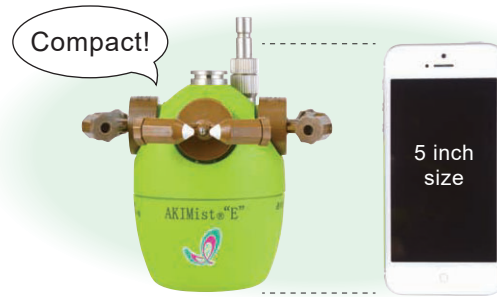

Features

- Quality fog reaches over four meters horizontally, providing effective humidification.*1
- Each AKIMist can accommodate up to four nozzles.
- Compact body structure keeps free from bacteria.
- Automatic humidity control is available with a humidity controller.

*1Spray length depends on the surrounding air temperature and humidity conditions.

Nozzle AKI03C



Long life technology

- Plastic nozzle tip is highly resistant to clogging.
- Main parts are quickly detachable by hand. Hand-screw plug with built-in packing makes maintenance easier.

Worn-out nozzles (or nozzle tips) can be replaced separately.

Nozzle tip set is available in sets of 10 pcs.

Applications

- Humidification: Textile factory, mushroom nursery, poultry incubation, fermentation room, cold storage for food, and more
- Moisture control: Textile, paper, plywood, etc.
- Preventing dust adhesion: Plastic molding, bag-making, painting line
- Dust suppression: Painting line, foundry, ceramic fabrication
- Curing: Concrete
- ESD prevention/Static electricity control: Printing, textile, painting line, plastic film, plastic molding, assembly line of electronics, paper, and more

High quality, silky Dry Fog

Nozzle type AKI 03C

Sauter mean droplet diameter: **7.5 μm** measured by a laser analyzer
 Spray volume: **2.4 L/hr** at 0.3 MPa (per nozzle) (air pressure)

AKI 03C nozzle type with clog-resistant nozzle tip produces non-wetting Dry Fog (ultra-fine fog) of uniform quality.

Our Dry Fog, with its ability to humidify target spaces without wetting nearby machines or products, is ideal for use in electronics factories or where wetting is not allowed.

03C Nozzle Performance (per nozzle)

Air pressure			Spray volume in L/hr (GPH)	Air consumption in L/min, Normal (SCFM)
MPa	bar	psi		
0.2	2	29	1.3 (0.34)	22 (0.82)
0.3	3	44	2.4 (0.63)	29 (1.08)
0.4	4	58	3.1 (0.82)	36 (1.34)
0.5	5	73	3.6 (0.95)	43 (1.60)

Note: Use under the air pressure of between 0.2 and 0.5 MPa (29 and 73 psi).

Specifications (per body)

Model No.	Number of nozzles	at air pressure of 0.3 MPa (44 psi)	
		Spray volume in L/hr (GPH)	Air consumption in L/min, Normal (SCFM)
AE-1 (03C)	1	2.4 (0.63)	29 (1.08)
AE-2 (03C)	2	4.8 (1.27)	58 (2.16)
AE-3 (03C)	3	7.2 (1.90)	87 (3.24)
AE-4 (03C)	4	9.6 (2.54)	116 (4.32)

One 03C nozzle should be good for spaces of 100 m³ (3,500 ft³), though it depends on various conditions.

Large volume fog

Nozzle type AKI 04E

Sauter mean droplet diameter: **10 μm** measured by a laser analyzer
 Spray volume: **3.0 L/hr** at 0.3 MPa (per nozzle) (air pressure)

04E nozzle type: Scratch-resistant nozzle tip, made of metal.

04E Nozzle Performance (per nozzle)

Air pressure			Spray volume in L/hr (GPH)	Air consumption in L/min, Normal (SCFM)
MPa	bar	psi		
0.2	2	29	1.9 (0.50)	27 (1.00)
0.3	3	44	3.0 (0.79)	36 (1.34)
0.4	4	58	3.8 (1.00)	45 (1.67)
0.5	5	73	4.5 (1.19)	54 (2.00)

Note: Use under the air pressure of between 0.2 and 0.5 MPa (29 and 73 psi).

Specifications (per body)

Model No.	Number of nozzles	at air pressure of 0.3 MPa (44 psi)	
		Spray volume in L/hr (GPH)	Air consumption in L/min, Normal (SCFM)
AE-1 (04E)	1	3.0 (0.79)	36 (1.34)
AE-2 (04E)	2	6.0 (1.58)	72 (2.67)
AE-3 (04E)	3	9.0 (2.38)	108 (4.00)
AE-4 (04E)	4	12.0 (3.17)	144 (5.34)

New Option

AKIMist "E" SETOJet Version | AE with SETO 05B or 075B

As the most clog-resistant option, the SETOJet version has been added to the AKIMist lineup. It is the ideal choice for worksites with high levels of airborne dust and frequent clogging problems. Please contact us for more details.



SETO 05B/075B nozzle is compatible with the existing AKIMist "E" humidifier.

Materials

- Body: PP, Stainless steel 303
- Nozzle: Stainless steel 303 (nozzle body & tip), PVC (cap & adaptor), PTFE (purge cap), FKM (O-ring & packing)
- Other parts: NBR, FKM (O-ring, Packing)

Model No.	AE-1		AE-2		AE-3		AE-4			
	SETO 05B	SETO 075B	SETO 05B	SETO 075B	SETO 05B	SETO 075B	SETO 05B	SETO 075B		
Nozzle type										
Number of nozzles	1		2		3		4			
Dimensions (mm) [width × height]	106 × 110		119 × 110							
Weight (g)	Net		310		330		360		390	
	Loaded		330		350		380		410	
Spray volume* (L/hr)	2.4		4.8		7.2		9.6			
Air consumption* (L/min, Normal)	45	60	90	120	135	180	180	240		
Mean droplet diameter* (μm)	10	9	10	9	10	9	10	9		
Air compressor motor power (kW)	0.75	0.75	1.5	1.5	1.5	2.2	2.2	2.2		

*Measured at air pressure of 0.3 MPa

Optional/Related products

AE-UT Adaptor (optional)



■ Aiming Dry Fog where needed



■ Intensive large volume spraying

AE-UT Adaptor provides flexibility to adjust the spray direction as needed and is installed between the nozzle and humidifier body. Easy to attach and remove by hand.

Chemical-resistant type is also available.

Note: Stop spraying before you change the direction.

Pipe Connection Kits (optional) for Easy Installation of AKIMist

Hanging-down (NP) Kit (w/o plate)

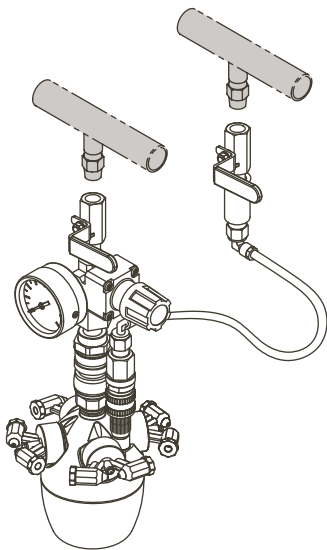

- Rc 1/4" threaded connection.

Wall Mounting Kit

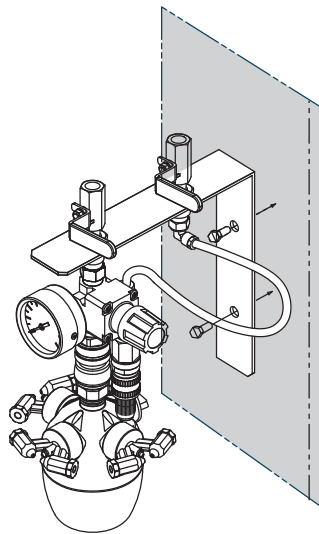

- Bolts to install the mounting plate are not included and need to be supplied by customer.
- The diameter of the holes on the plate is 9 mm.
- Rc 1/4" threaded connection.

Hanging-down Kit

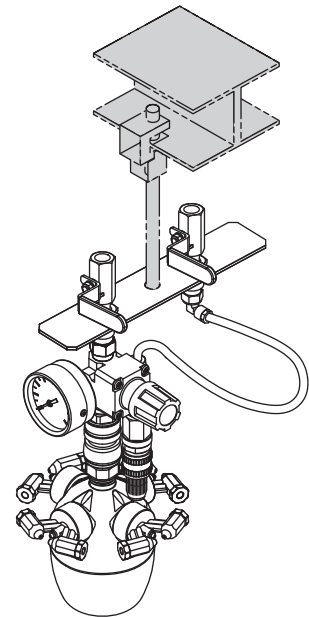

- Bolts and hanging fixture are not included and need to be supplied by customers.
- The diameter of hole on the plate is 11 mm.
- Rc 1/4" threaded connection.

Note: Gray parts are NOT included in the kit. These kits come assembled.
These pipe connection kits are not chemical resistant.

How to order

Please use this coding system to send an inquiry or to order for a specific model.

To add a pipe connection kit, please specify the type of connection kit.

<Example> AE-1 (03C) + Hanging-down Kit

Note:

- Up to four nozzles can be mounted on one AKIMist "E".
- Oil-free options are available at additional cost. Contact us for details.

AE-

1

Number of nozzles

- 1
- 2
- 3
- 4

(03C)

Nozzle type

- (03C)
- (04E)
- Made-to-order:
- (SETO05B)
- (SETO075B)

+

Hanging-down Kit

Type of pipe connection kit

- Hanging-down (NP) Kit (w/o plate)
- Wall Mounting Kit
- Hanging-down Kit

Chemical-resistant AKIMist® "E" TN



(Available only with nozzle type AKI03C)

Titanium is applied to the liquid contact parts, for spraying of chemical solution.

Note: This product is sold without pipe connection kit.

Applications

- Disinfection, sterilization in food factories, hospitals/ pharmaceutical plants
- Disinfection, deodorization in egg farms, livestock barns

Easy DIY Kit

Dry Fog Humidifier Kit

AE-KIT

This easy DIY kit includes all components for efficient humidification. No complicated setup needed: just supply the electricity and compressed air.

- You can choose the contents of AE-KIT freely to suit your factory size and layout.
- Includes piping and connectors for tap water and air, you can install them easily, and keep optimal humidity. (Wall-mounting type)
- One AE-KIT can humidify an 800 m³ area. Please contact IKEUCHI for an inquiry sheet and technical drawing.

Includes:

Nozzle unit (AKIMist "E"), Control unit, Water filter unit, and Piping unit

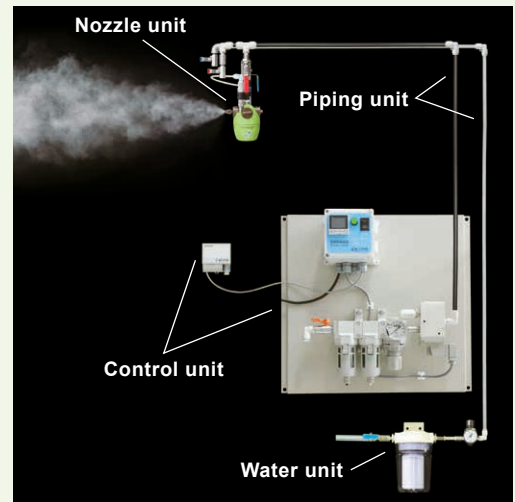

No Piping Needed!

Portable Dry Fog Humidifier Set

AE-T set

No piping work necessary.

Easy, convenient humidification for immediate usage in any place with an air supply.

- The portable AE-T set comes with a stand and pressure tank and can be used anywhere; it only needs to be connected to compressed air.
- Easy automatic control with a humidity controller (optional).
- Ideal for spot humidification around machinery and use in a small space up to 100 m³.

Includes:

AKIMist "E", Stand with wheels, Telescopic pole, Water tank, Gauge-mounted pressure regulators, and Mounting unit

Option Compact humidity controller set

Specifications

Tank capacity	Material	Max. pressure	Weight	Pole height
18 L (4.8 gal)	Stainless steel 304 etc.	0.7 MPa (100 psi)	12.4 kg (loaded: 30.4 kg) 28 lb (loaded: 67 lb)	Min. 1,000– Max. 2,380 mm

Note: Safety valve is set at 0.4 MPa.

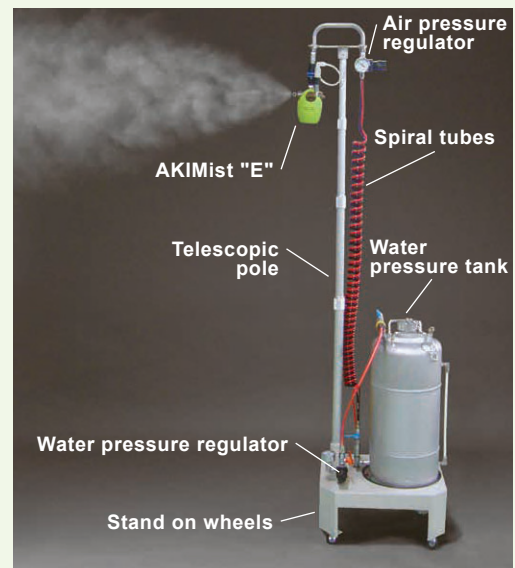

Installation & Ancillary Devices

For minimal maintenance and long life, clean air and purified water must be supplied to the system. IKEUCHI, having vast expertise, provides a wide range of ancillary devices for purifying water/air and automatic humidity control.

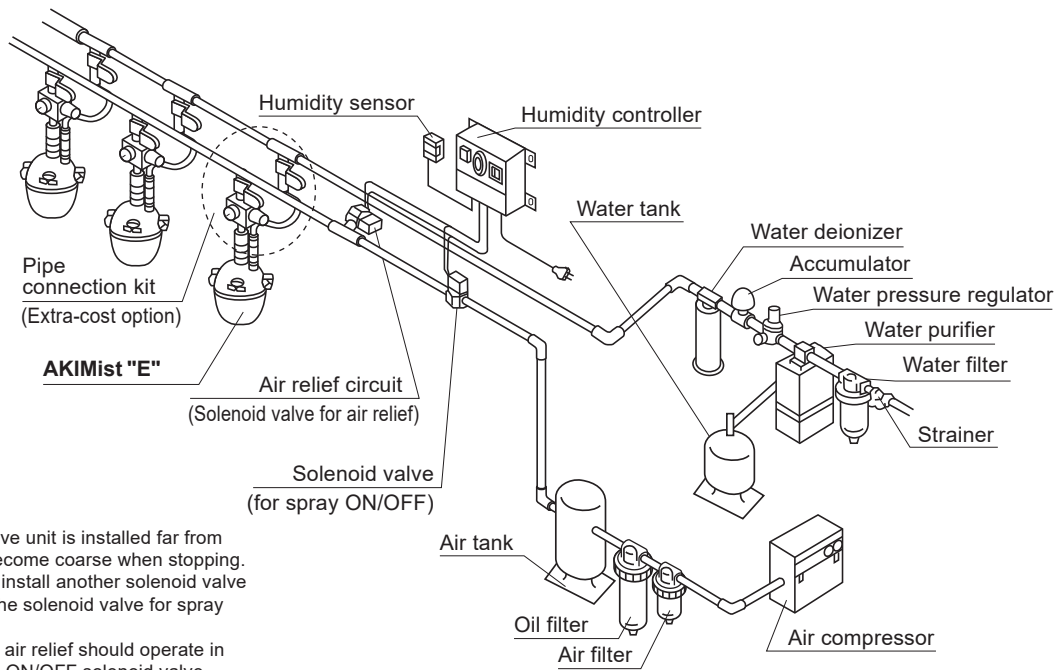

Air relief circuit

When the solenoid valve unit is installed far from AKIMist, spray may become coarse when stopping. In such cases, please install another solenoid valve for air relief between the solenoid valve for spray ON/OFF and AKIMist.

The solenoid valve for air relief should operate in reverse with the spray-ON/OFF solenoid valve.

Automatic Humidity Control

Humidity Controller RHC-C11



Compact size to fit any place, with digital display of present humidity and target humidity.

Solenoid Valve Unit

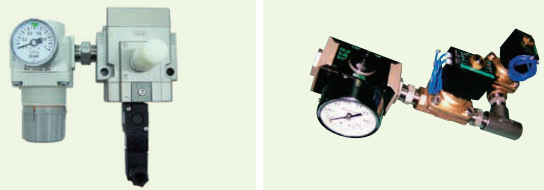

3-way Solenoid Valve Unit 2-way Solenoid Valve Unit

Humidity controller, humidity sensor, and solenoid valve unit work together to control automatic spray ON/OFF operation and maintains the desired humidity level.

Liner Humidity Control

RHC-D41C automatically adjusts the spray volume by controlling the spray pressure of AKIMist humidifiers depending on the present humidity.

Used with our electro-pneumatic regulator unit and humidity sensor, the controller increases the spray pressure to increase the spray volume when humidity is low and reduces the spray pressure for reduced spray volume when the humidity approaches the set humidity level. This control approach prevents over-humidification and achieves an energy-efficient, stable humidity environment.

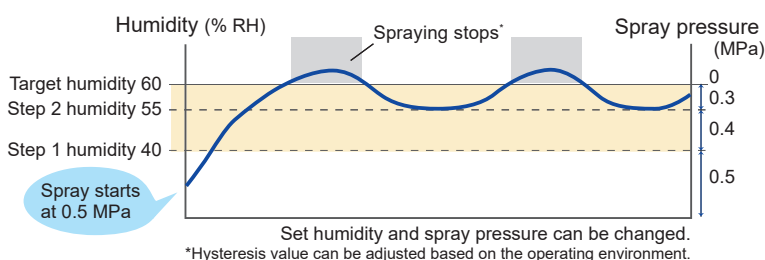

Humidity Controller RHC-D41C



Up to four areas can be individually controlled with a single controller. (Humidity sensors are sold separately)

Electro-pneumatic Regulator Unit



Air Filter

- For removal of dust and moisture contents over 0.3 μm from the compressed air with micro-fiber.
- Available in a variety of sizes.
- Air ancillary device set includes an air filter and oil filter with a manual discharging drain and nipple.



Water Filter

- For removal of foreign particles over 5 μm.
- Available in a variety of sizes.
- Water ancillary device set includes a water filter, a pressure regulator and nipple.



Recommended Pipe Size Chart (when using nozzle type 03C)

The total number of 03C nozzles		1	2	3	4	5	6	7	8	9	10	11	12	13	14	15	16	17	18	19	20	21	22	23	24	25	26	27	28	29	30	31	32	33
Air consumption	L/min, Normal (SCFM)	29 L/min, Normal (1.08 SCFM) × the number of nozzles																																
Water consumption	L/hr (GPH)	2.4 L/hr (0.63 GPH) × the number of nozzles																																
Recommended pipe size (Stainless steel pipes should be used)	Air	1/4" or over				3/8" or over				1/2" or over								3/4" or over																
	Water	1/4" or over				3/8" or over												1/2" or over																

If you plan to use AKI 04E or SETO 05B/075B nozzles, please contact us.

Air Compressor Selection Chart (when using nozzle type 03C)

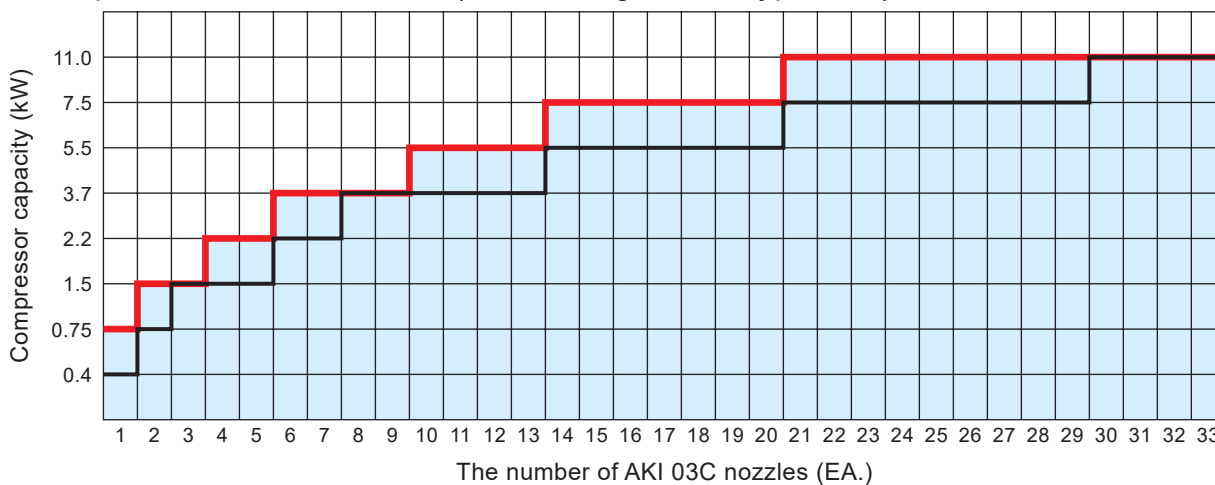

- Notes:
1. When spraying at 0.3 MPa air pressure, please refer to the black line (—).
When spraying at 0.5 MPa air pressure, please refer to the red line (—).
 2. Type of compressor: reciprocating compressor for 0.4–7.5 kW and a screw compressor for 11 kW.
 3. Using this chart as a target, consult your compressor catalog and confirm the output capacity.

AKIMist "E" Humidifier Operating Conditions

For minimal maintenance requirements and long life, provide clean air and purified water, and follow the conditions listed below.

	Air	Water
Operating pressure range	0.2–0.5 MPa (29–73 psi)	0.05–0.4 MPa (8–58 psi) Note: Even if set within given range, water pressure may temporarily exceed 0.2 MPa due to operating and other conditions. The recommended setting is 0.1 MPa (15 psi).
Temperature	5°C (41°F)–Room temperature	Room temperature
Quality	Air without moisture, oil mist, or dust; Dew point 10°C.	No particles. Electric conductivity = 0.07–10 micro-S/cm (Resistivity 14–0.1 MΩ•cm)

Benefits of Humidification

1. Static Charge Prevention

Helps to eliminate static electricity problems, improve product quality, and reduce the number of defects.

■ Relation between humidity and static charge

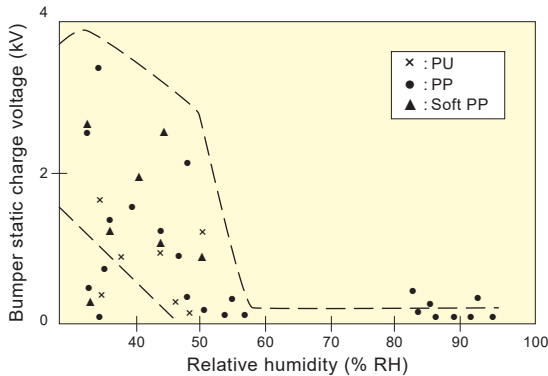

By maintaining humidity at 60% RH or higher, the electrostatic charge on bumpers is reduced dramatically.

■ Monthly defect counts and absolute humidity levels (IC memory assembly process)

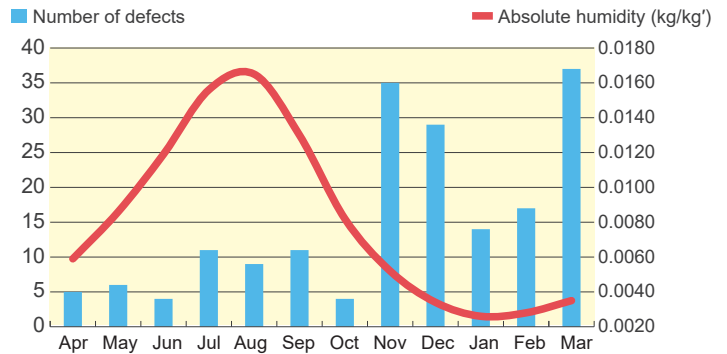

As humidity decreases, the number of defects increases, particularly with ultra-small components that are more susceptible to static charge.

2. Energy-Saving Effect

Our Dry Fog humidification system also yields a cooling of about 2°C, which helps to reduce air conditioning cooling costs.

Energy cost for Dry Fog humidification is less than one-third of that for steam humidification.

■ Humidification and cooling effects

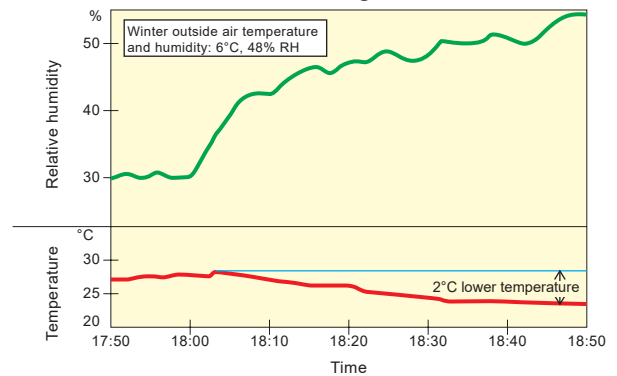

■ Comparison of the operating cost of humidification methods

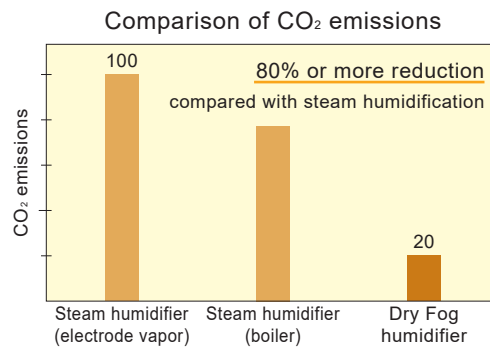
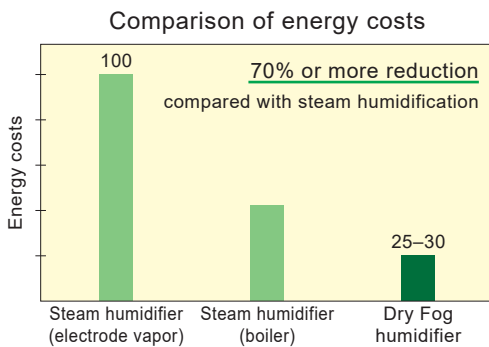

3. Promoting Better Worker Health

Many of our customers say, "Worker absences caused by illness has reduced after the installation of AKIMist. Maintaining a relative humidity level over 50% dramatically reduces cold viruses, flu viruses and so forth, and creates more comfortable working environments.

Humidity over 50% RH cuts the lifespan of cold and flu viruses, helping to reduce worker's sick days.

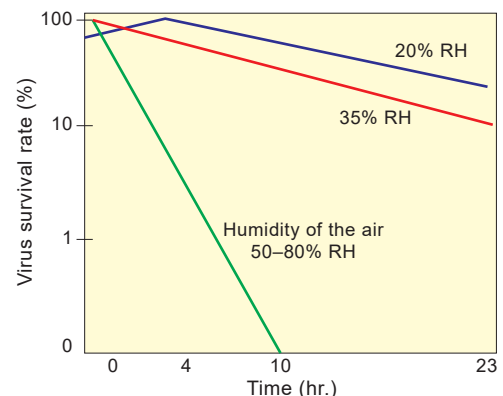

Customer Case Studies

1. Printing Web Offset Printing Process

Humidity control suited to each printing press type and process has a big impact.

- AKIMist has quickly gained acceptance as nozzle-type humidification systems are becoming popular in the printing industry.
- AKIMist has the best track record in the Japanese printing industry, with over 30 years of strong experience.
- For sheet-fed printing, UV printing, Flexo printing and others, we have the best-suited solutions for all kinds of printing presses.

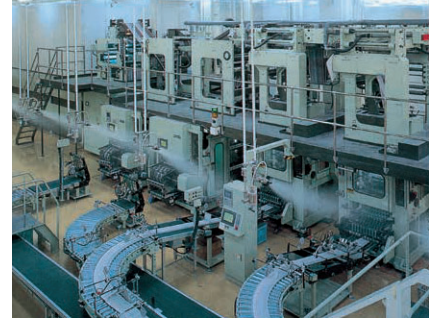

Improved productivity and quality, reduced waste paper

Paper jams, poor folds, etc. ➡ Solved by controlling humidity to around 50% RH

2. Electronics SMT Process

A humidification method that can save energy has become the strongest focus of attention.

- By maintaining humidity at an appropriate level, it is possible to prevent the various problems caused by static electricity.
- The Dry Fog cooling effect reduces the building cooling load.
- With the No. 1 track record as well as 30 years of remarkably good results, we have optimal solutions for a wide range of processes and environments.
- It is also well-suited for clean room humidification.



Reduced pickup and mount errors by 60% and cooling load by 20%

Internal part damage ➡ Solved by controlling humidity to around 45% RH

3. Painting Painting Process for Cars

Control ambient humidity to eliminate static electricity and limit airborne waste.

- By keeping appropriate humidity, dust is suppressed and static electricity is reduced.
- Humidification is the first step to reduce the adhesion of dust to products.
- Starting with the car industry, AKIMist is now used in many kinds of industry as the solution for dust problems.
- We can find solutions to meet the needs of your factory.

Reduced adhesion of particles

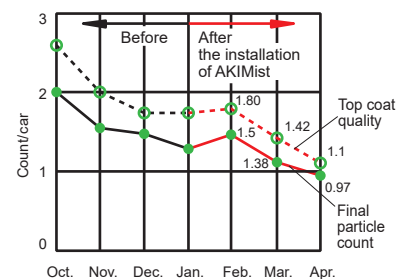

Reduced adhesion of dust by 20% and maintaining operators' health

Defective painting by adhesion of dust ➡ Solved by controlling humidity to about 50% RH

Other Installations

Field	Goal	Examples of actual results
Textiles	Improved productivity	<ul style="list-style-type: none"> ● Thread breakage is prevented and productivity improved. ● Prevented pass weft from sticking. ● Prevented defects due to static electricity.
Chemicals	Safety precautions	<ul style="list-style-type: none"> ● Reduced the risk of ignition in paint and ink mixing processes. ● Allowed humidification for processes where it had been previously thought impossible. ● Reduced risk of fire, which could lead to loss of life and loss of public trust.

We have numerous proven solutions for industries beyond the above cases.

These effects depend on factory conditions.

Spray Droplet Size by Various Humidifiers

Shown below are pictures of droplets collected by Immersion Sampling and droplet diameter distribution measured by the laser analyzer.

(The vertical axis is for droplet diameter, and the horizontal for the proportional number of droplets.)

AKIMist "E" 03C/04E nozzle type (Dry Fog)

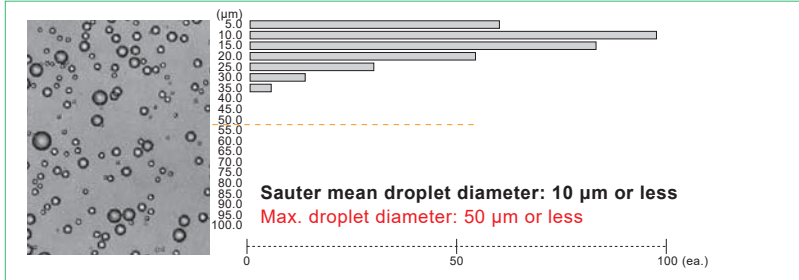

Why Dry Fog doesn't get things wet:

Uniform fog, having no large droplets, humidifies target spaces effectively without getting anything wet.

We define Dry Fog as a very fine fog with a uniform, mean droplet diameter (average fog droplet size) of 10 μm or less.

Other kinds of humidifiers

●Conventional pneumatic spray nozzle

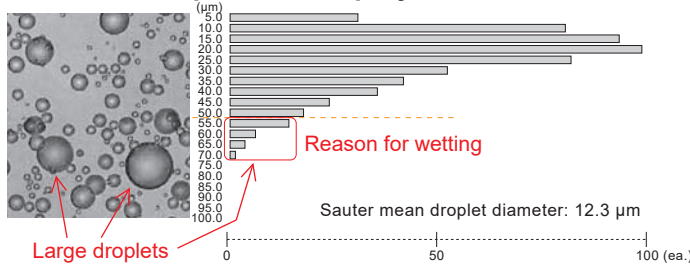

Why other humidifiers wet things:

Even though the mean droplet diameter is small, large droplets included in spray distributions will eventually cause wetting.

●Spinning disk type

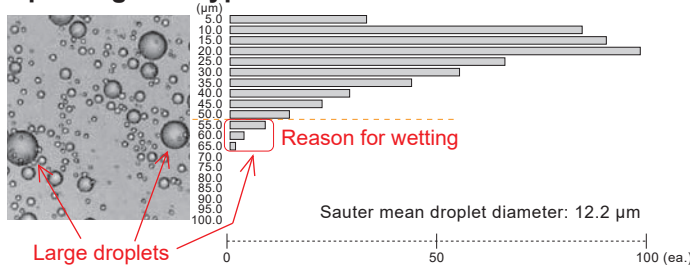

●Ultrasonic type

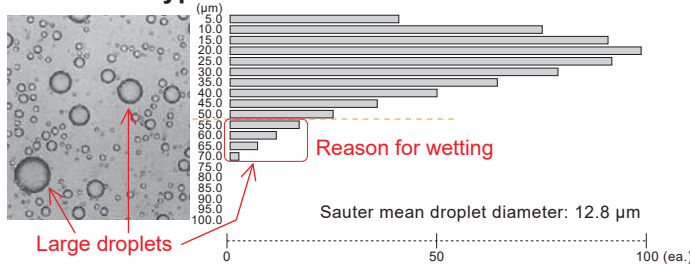

Note: Specifications and contents noted in this catalog are subject to change without prior notice.



"The Fog Engineers"

H. IKEUCHI & CO., LTD.

<https://www.kirinoikeuchi.co.jp/eng/>



ISO9001: 2015 certified
(H. IKEUCHI & CO., LTD., Japan only)

Headquarters

Daiichi Kyogyo Bldg., 1-15-15 Awaza
Nishi-ku, Osaka 550-0011, Japan
Tel: 81-6-6538-4015 Fax: 81-6-6538-4022
overseas@kirinoikeuchi.co.jp



IKEUCHI (SHANGHAI) CO., LTD.

Room C, 21F, Electrical & Mechanical Bldg., 600 Hengfeng Road, Shanghai 200070, P.R.China
Tel: 86-21-6140-9731

mist@kirinoikeuchi.com <http://www.kirinoikeuchi.com/>

Tianjin Branch Tel: 86-22-2320-1676

Shenzhen Branch Tel: 86-755-8525-2221

Wuhan Branch Tel: 86-27-8558-8299

IKEUCHI USA, INC.

4722 Ritter Avenue, Blue Ash, OH 45242, USA
Tel: 1-513-942-3060 sales@ikeuchi.us <https://www.ikeuchi.us/>

IKEUCHI EUROPE B.V.

Merwedeweg 6, 3621 LR, Breukelen, The Netherlands
Tel: 31-20-820-2175 info@ikeuchi.eu <https://www.ikeuchi.eu/>

Ikeuchi Taiwan Co., Ltd.

11F-1, No. 27, Sec. 1, Chung Shan N. Rd., Taipei, 10441, Taiwan R.O.C.
Tel: 886-2-2511-6289 Fax: 886-2-2541-6392 sales@ikeuchi.com.tw www.ikeuchi.com.tw/

PT. IKEUCHI INDONESIA

Ruko Rodeo Drive, Jl. Hollywood Boulevard Blok B6 No. 18 & 19, Jababeka, Bekasi, Jawa Barat 17530 Indonesia
Tel: 62-21-8938-4201 (or 4202) sales@ikeuchi.id <https://www.ikeuchi.id/>

SIAM IKEUCHI CO., LTD.

909 Ample Tower Bldg. 8FL., Unit 8/2, 8/3, Debaratana Road, Bangna Nuea, Bangna, Bangkok 10260 Thailand
Tel: 66-2-348-3801 Fax: 66-2-348-3802 thai@ikeuchi.co.th <https://www.ikeuchi.co.th/>